

WAGNER

Originalbetriebsanleitung

Airless – Hochdruck Spritzgerät

Betriebsanleitung 2

Airless high-pressure spraying unit

Operating manual 34

Appareil de pulvérisation à haute pression Airless

Mode d'emploi 65

Apparecchio di verniciatura a spruzzo Airless ad alta pressione

Istruzioni per l'uso 97

Super Finish 23 PLUS

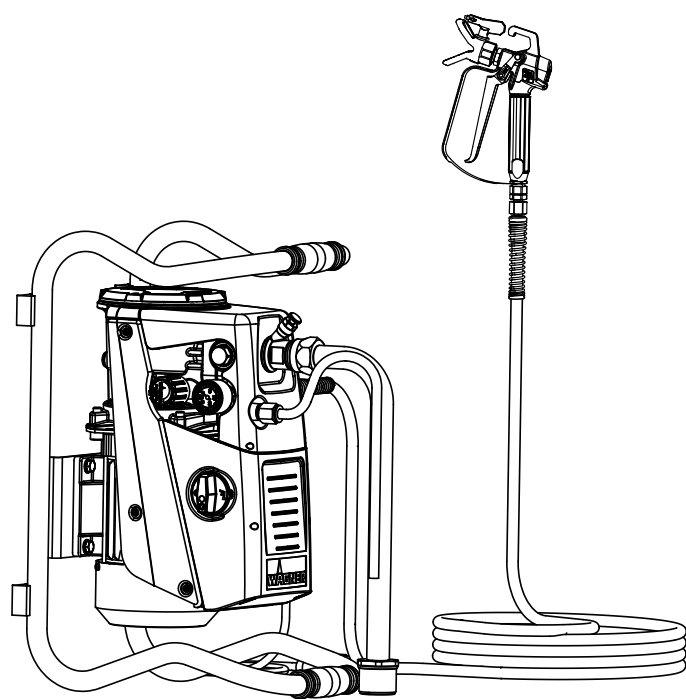

2334 424

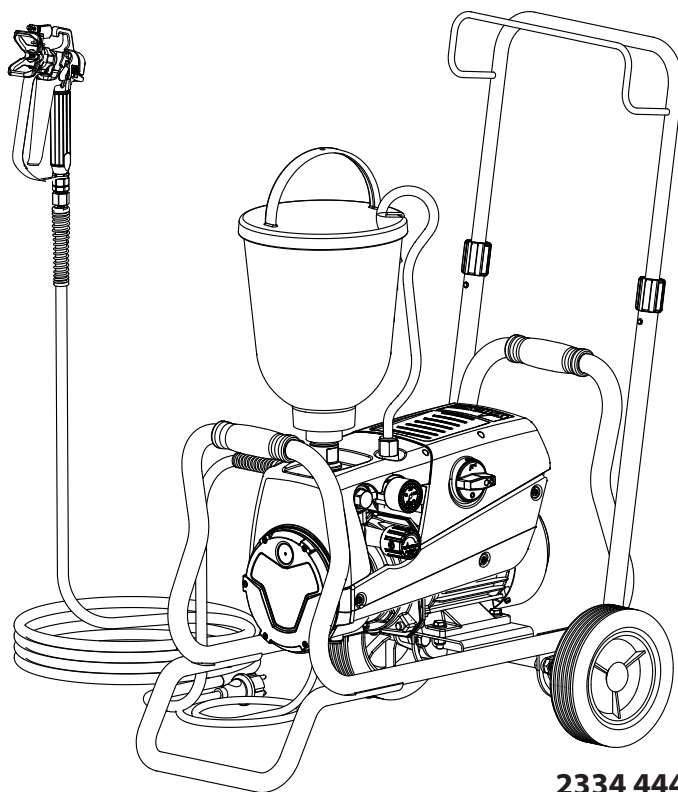

2334 444

Contents

1	SAFETY REGULATIONS FOR AIRLESS SPRAYING	36			
1.1	Flash point	36			
1.2	Explosion protection	36			
1.3	Danger of explosion and fire from sources of ignition during spraying work	36			
1.4	Danger of injury from the spray jet	36			
1.5	Secure spray gun against unintended operation	36			
1.6	Recoil of spray gun	36			
1.7	Breathing equipment as protection against solvent vapors	36			
1.8	Prevention of occupational illnesses	36			
1.9	Max. operating pressure	37			
1.10	High-pressure hose	37			
1.11	Electrostatic charging (formation of sparks or flames)	37			
1.12	Use of units on building sites and workshops	37			
1.13	Socket at the unit	37			
1.14	Ventilation when spraying in rooms	37			
1.15	Suction installations	37			
1.16	Earthing of the object	37			
1.17	Cleaning the unit with solvents	37			
1.18	Cleaning the unit	37			
1.19	Work or repairs at the electrical equipment	37			
1.20	Work at electrical components	38			
1.21	Setup on an uneven surface	38			
2	GENERAL VIEW OF APPLICATION	38			
2.1	Application	38			
2.2	Coating material	38			
2.2.1	Coating materials with sharp-edged additional materials	38			
2.2.2	Filtering	39			
3.	DESCRIPTION OF UNIT	39			
3.1	Airless process	39			
3.2	Functioning of the unit	39			
3.3	Explanatory diagram	40			
3.4	Transportation	40			
3.5	Trolley backfitting	41			
3.6	Technical data	41			
4	STARTUP	42			
4.1	Unit with suction system	42	4.6	Cleaning preserving agent when starting-up of operation initially	42
4.2	unit with upper hopper (5 litres)	42	4.7	Ventilate unit (hydraulic system) if the sound of inlet valve is not audible	42
4.3	high pressure hose and spray gun	42	4.8	Taking the unit into operation with coating material	42
4.4	Connection to the mains network	42	5	SPRAYING TECHNOLOGY	44
4.5	Socket on unit (not included in all models)	43	6	HANDLING THE HIGH-PRESSURE HOSE	44
			7	INTERRUPTION OF WORK	44
			8	CLEANING THE UNIT	45
			8.1	Cleaning the unit from the outside	46
			8.2	Suction filter	46
			8.3	High-pressure filter	46
			8.4	Cleaning the Airless spray gun	47
			9	SERVICING	47
			9.1	General servicing	47
			9.2	High-pressure hose	47
			10	REPAIRS AT THE UNIT	48
			10.1	Inlet valve Pusher	48
			10.2	Inlet valve	48
			10.3	Outlet valve	49
			10.4	Pressure control valve	49
			10.5	Replacing the power cable	50
			10.6	Typical wear parts	50
			10.7	Connection diagram	51
			10.8	Remedy in case of faults	52
			11	SPARE PARTS AND ACCESSORIES	53
			11.1	Super Finish 23 PLUS accessories	53
			11.2	Spare parts list Super Finish 23 PLUS	58
			11.3	Spare parts list high-pressure filter	60
			11.4	Spare parts List Trolley	60
			11.5	Spare parts List frame	61
			11.6	Spare parts list suction system (rigid)	61
			11.7	Spare parts list hopper 5l	62
			11.8	Spare parts list hopper with TopClean	62
				Testing of the unit	63
				Important information on product liability	63
				Note on disposal	63
				Guarantee declaration	63
				CE - declaration	129
				European service network	132

1 SAFETY REGULATIONS FOR AIRLESS SPRAYING

All local safety regulations in force must be observed. The following sources are just a sample of those containing safety requirements for Airless spraying.

- a) The European Standard „Spray equipment for coating materials – safety regulations,, (EN 1953).

The following safety regulations are to be observed in order to ensure safe handling of the Airless high-pressure spraying unit.

1.1 FLASH POINT

 Danger	<p>Only spray coating materials with a flash point of 21 °C or higher. The flash point is the lowest temperature at which vapors develop from the coating material. These vapors are sufficient to form an inflammable mixture over the air above the coating material.</p>
---	---



1.2 EXPLOSION PROTECTION

 Danger	<p>Do not use the unit in work places which are covered by the explosion protection regulations. The unit is not designed to be explosion protected. Do not operate the device in explosive areas (zone 0, 1 and 2). Explosive areas are, for example, places where paints are stored and locations in direct proximity to the object being sprayed. Keep the device at least 3 m from the object you are spraying.</p>
---	---

1.3 DANGER OF EXPLOSION AND FIRE FROM SOURCES OF IGNITION DURING SPRAYING WORK

 Danger	<p>There must be no sources of ignition such as, for example, open fires, lit cigarettes, cigars or tobacco pipes, sparks, glowing wires, hot surfaces, etc. in the vicinity.</p>
---	---

1.4 DANGER OF INJURY FROM THE SPRAY JET

 Danger 	<p>Attention, danger of injury by injection! Never point the spray gun at yourself, other persons or animals. Never use the spray gun without spray jet safety guard. The spray jet must not come into contact with any part of the body. In working with Airless spray guns, the high spray pressures arising can cause very dangerous injuries. If contact is made with the spray jet, coating material can be injected into the skin. Do not treat a spray injury as a harmless cut. In case of injury to the skin by coating material or solvents, consult a doctor for quick and correct treatment. Inform the doctor about the coating material or solvent used.</p>
---	--

1.5 SECURE SPRAY GUN AGAINST UNINTENDED OPERATION

Always secure the spray gun when mounting or dismounting the tip and in case of interruption to work.

1.6 RECOIL OF SPRAY GUN

 Danger	<p>When using a high operating pressure, pulling the trigger guard can effect a recoil force up to 15 N. If you are not prepared for this, your hand can be thrust backwards or your balance lost. This can lead to injury.</p>
--	---

1.7 BREATHING EQUIPMENT AS PROTECTION AGAINST SOLVENT VAPORS

Wear breathing equipment during spraying work. A breathing mask is to be made available to the user.

1.8 PREVENTION OF OCCUPATIONAL ILLNESSES

Protective clothing, gloves and possibly skin protection cream are necessary for the protection of the skin.

Observe the regulations of the manufacturer concerning coating materials, solvents and cleaning agents in preparation, processing and cleaning units.

1.9 MAX. OPERATING PRESSURE

The permissible operating pressure for the spray gun, spray gun accessories, unit accessories and high-pressure hose must not fall short of the maximum operating pressure of 25 MPa (250 bar or 3625 psi).

1.10 HIGH-PRESSURE HOSE

 Danger	<p>Attention, danger of injury by injection! Wear and tear and kinks as well as usage that is not appropriate to the purpose of the device can cause leakages to form in the high-pressure hose. Liquid can be injected into the skin through a leakage.</p>
-------------------	--

- High-pressure hoses must be checked thoroughly before they are used.
- Replace any damaged high-pressure hose immediately.
- Never repair defective high-pressure hoses yourself!
- Avoid sharp bends and folds: the smallest bending radius is about 20 cm.
- Do **not drive over** the high-pressure hose. Protect against sharp objects and edges.
- Never pull on the high-pressure hose to move the device.
- Do not twist the high-pressure hose.
- Do not put the high-pressure hose into solvents. Use only a wet cloth to wipe down the outside of the hose.
- Lay the high-pressure hose in such a way as to ensure that it cannot be tripped over.

	<p>Only use WAGNER original-high-pressure hoses in order to ensure functionality, safety and durability.</p>
--	--

1.11 ELECTROSTATIC CHARGING (FORMATION OF SPARKS OR FLAMES)

 Danger	<p>Electrostatic charging of the unit may occur during spraying due to the flow speed of the coating material. These can cause sparks and flames upon discharge. The unit must therefore always be earthed via the electrical system. The unit must be connected to an appropriately-grounded safety outlet.</p>
-------------------	--

An electrostatic charging of spray guns and the high-pressure hose is discharged through the high-pressure hose. For this reason the electric resistance between the connections of the high-pressure hose must be equal to or lower than 1 MΩ.

1.12 USE OF UNITS ON BUILDING SITES AND WORKSHOPS

The unit may only be connected to the mains network via a special feeding point with a residual-current device with INF ≤ 30 mA.

1.13 SOCKET AT THE UNIT

Do not load the socket with more than 1500 Watt. Unroll any connected cable drum completely.

1.14 VENTILATION WHEN SPRAYING IN ROOMS

Adequate ventilation to ensure removal of the solvent vapors has to be ensured.

1.15 SUCTION INSTALLATIONS

The are to be provided by the unit user in accordance with the corresponding local regulations.

1.16 EARTHING OF THE OBJECT

The object to be coated must be earthed. (Building walls are usually earthed naturally)

1.17 CLEANING THE UNIT WITH SOLVENTS

 Danger	<p>When cleaning the unit with solvents, the solvent should never be sprayed or pumped back into a container with a small opening (bunghole). An explosive gas/air mixture can arise. The container must be earthed.</p>
-------------------	--

1.18 CLEANING THE UNIT

 Danger	<p>Danger of short-circuits caused by water ingression! Never spray down the unit with high-pressure or high-pressure steam cleaners.</p>
-------------------	--

1.19 WORK OR REPAIRS AT THE ELECTRICAL EQUIPMENT

These may only be carried out by a skilled electrician. No liability is assumed for incorrect installation.

1.20 WORK AT ELECTRICAL COMPONENTS

Unplug the power plug from the outlet before carrying out any repair work.

1.21 SETUP ON AN UNEVEN SURFACE

The front end must always point downwards in order to avoid sliding away.

If possible do not use the unit on an inclined surface since the unit tends to wander through the resulting vibrations.

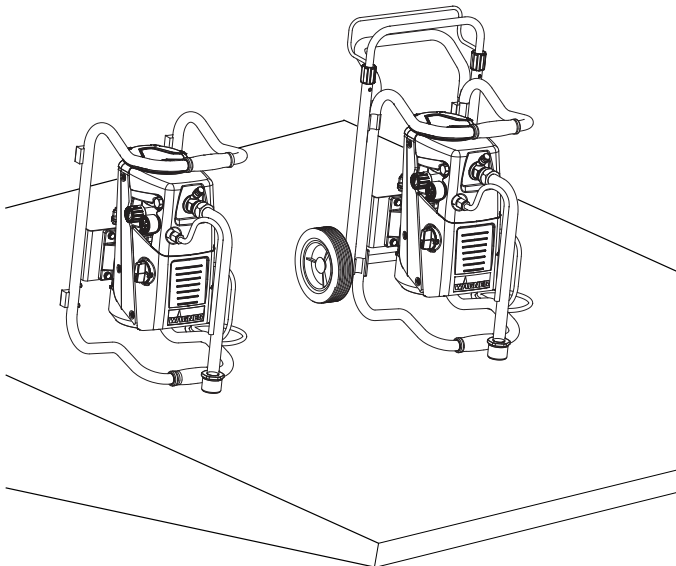
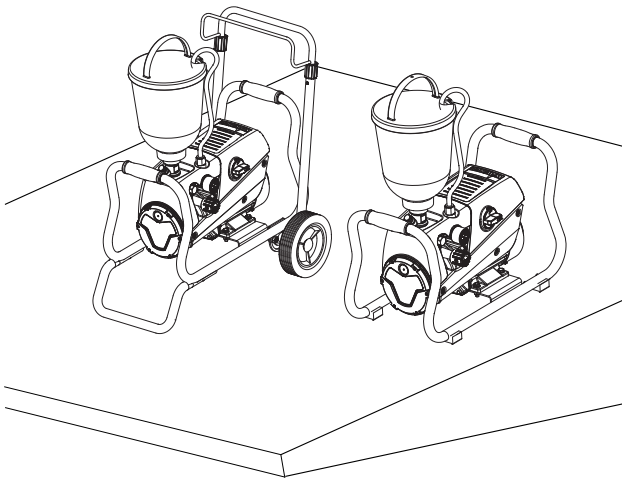

2 GENERAL VIEW OF APPLICATION

2.1 APPLICATION

Super Finish 23 PLUS is an electric driven unit for the airless atomization of different painting materials. Also it is able to feed the internal feeded paint roller, which is available as accessory.

Super Finish 23 PLUS is made for jobs in the workshop and on the building site.

The unit performance is conceived so that its use is possible on building sites for small- to middle-area dispersion work.

When painting, the device is suitable for all kinds of typical painting jobs, e.g.:

doors, door frames, balustrades, furniture, woodencladding, fences, radiators (heating) and steel parts.

We recommend using the top container for paintwork.

2.2 COATING MATERIAL

Diluting lacquers and paints or those containing solvents, two-component coating materials, dispersion and latex paints.

No other materials should be used for spraying without WAGNER's approval.



Pay attention to the Airless quality of the coating materials to be processed.

The unit is able to process coating materials with up to 20,000 mPas. If highly viscous coating materials cannot be taken in or the performance of the unit is too low, the paint must be diluted in accordance with the manufacturer's instructions.



Attention: Make sure, when stirring up with motor-driven agitators that no air bubbles are stirred in. Air bubbles disturb when spraying and can, in fact, lead to interruption of operation.

2.2.1 COATING MATERIALS WITH SHARP-EDGED ADDITIONAL MATERIALS

These particles have a strong wear and tear effect on valves and tips, but also on the heating hose and spray gun. This impairs the durability of these wearing parts considerably.

2.2.2 FILTERING

Sufficient filtering is required for fault-free operation. To this purpose the unit is equipped with a suction filter (Item 1) and an insertion filter in the spray gun (Item 2). Regular inspection of these filters for damage or soiling is urgently recommended.

A high-pressure filter (Item 3) -available as accessory- is rising up the filtering surface and will make the work more comfortable.

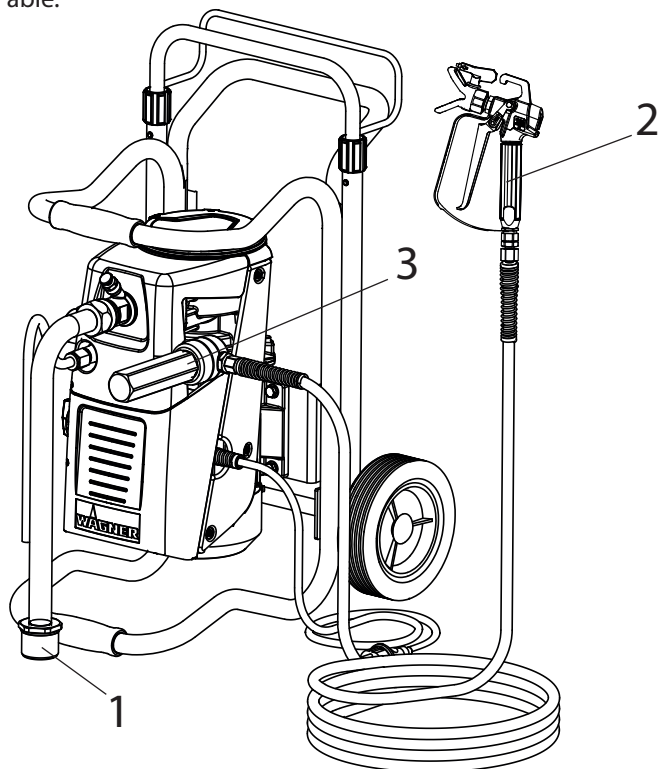

3. DESCRIPTION OF UNIT

3.1 AIRLESS PROCESS

The main area of application are thick layers of highly viscous coating material.

At the Super Finish 23 PLUS unit a diaphragm pump takes in the coating materials and transports it via a high-pressure hose to the spray gun with the airless tip. Here the coating material atomizes since it is pressed through the tip core at a maximum pressure of 25 MPa (250 bar, 3625 psi). This high pressure has the effect of micro fine atomisation of the coating material.

As no air is used in this process, it is described as an AIRLESS process.

This method of spraying has the advantages of finest atomisation, cloudless operation (depending of a correct unit adjustment) and a smooth, bubblefree surface. As well as these, the advantages of the speed of work and convenience must be mentioned.

3.2 FUNCTIONING OF THE UNIT

The following section contains a brief description of the technical construction for better understanding of the function:

Super Finish 23 PLUS is an electrically driven high-pressure paint spraying equipment.

The electric motor (1) drives the hydraulic pump via planetary gears (2). A piston (3) is moved up and down so that hydraulic oil is moved under the diaphragm (4) which then moves.

In detail:

The downwards movement of the machine opens the disk inlet valve (5) automatically and coating material is sucked in. During the upwards movement of the diaphragm, the coating material is displaced and the outlet valve opens while the inlet valve is closed.

The coating material flows under high pressure through the high-pressure hose to the spray gun and is atomized when it exists from the tip.

The pressure control valve limits the set pressure in the hydraulic oil circuit and thus also the pressure of the coating material.

A pressure change when the same tip is used also leads to a change in the amount of paint atomized.

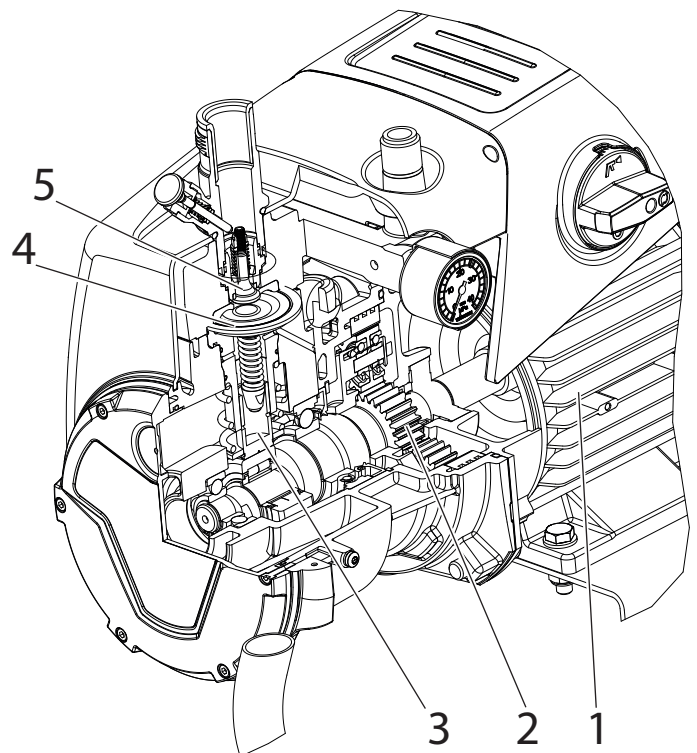

DESCRIPTION OF UNIT

3.3 EXPLANATORY DIAGRAM

- 1 Tip guard with airless tip
- 2 Spray gun
- 3 High-pressure hose
- 4 Connection for high-pressure hose
- 5 Pressure gauge
- 6 Pressure control valve
- 7 Multifunction switch

Symbols (shown in the recess of the switch):

- 0** OFF
- ON / Circulation
- ON / Spraying

- 8 Return tube
- 9 Suction tube
- 10 Hopper
- 11 Inlet valve button
- 12 Outlet valve
- 13 Socket, max. load 1500 Watt
(not included in all models)

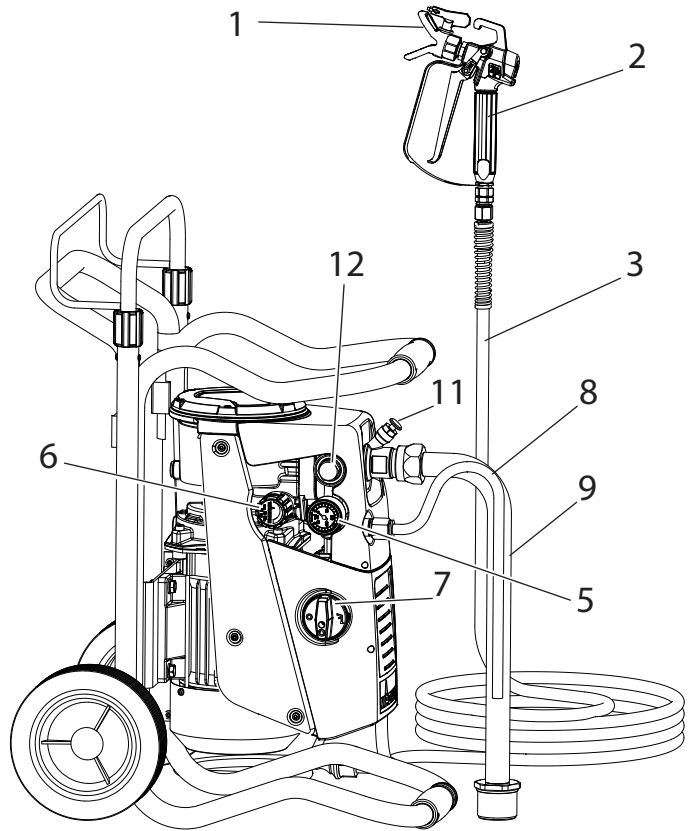

3.4 TRANSPORTATION

Unroll high-pressure hose and lay it over the shaft.

Loosen terminal sleeves (item 1) on the shaft (U open). Extract shaft to the desired length. Tighten terminal sleeves again by hand (U closed).

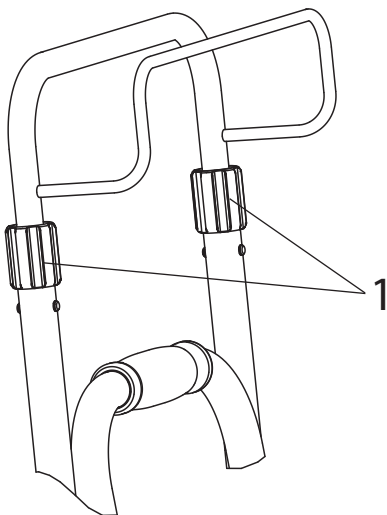

Transportation in vehicle

Secure the unit in the vehicle by means of suitable fasteners. The device can be placed on its side if necessary. In this case, please ensure that no attachments can be damaged. Attention: Paint or solvent residues can escape from the connections!

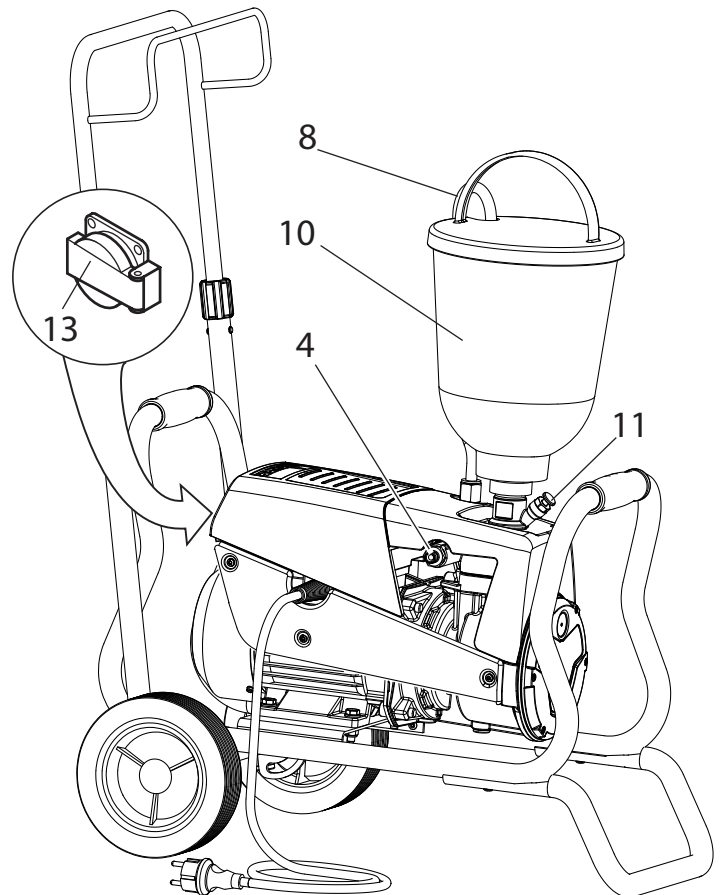

3.5 TROLLEY BACKFITTING

	Before start with the backfitting, pull of main plug of socket, disassemble suction system and high pressure hose
---	---

When changing between the top container and the suction system, the carriage needs to be altered.

1. Unscrew the screws (pos. 1) with the attached wrench (17 mm).
2. Tilt the shaft and align the Super Finish 23 PLUS in the required position:
 - a) Operate with suction system
 - b) Operate with top container
3. Re-tighten the screws.

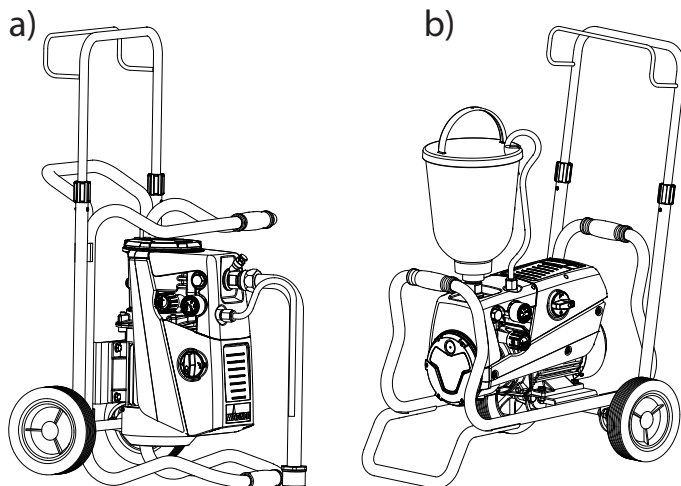
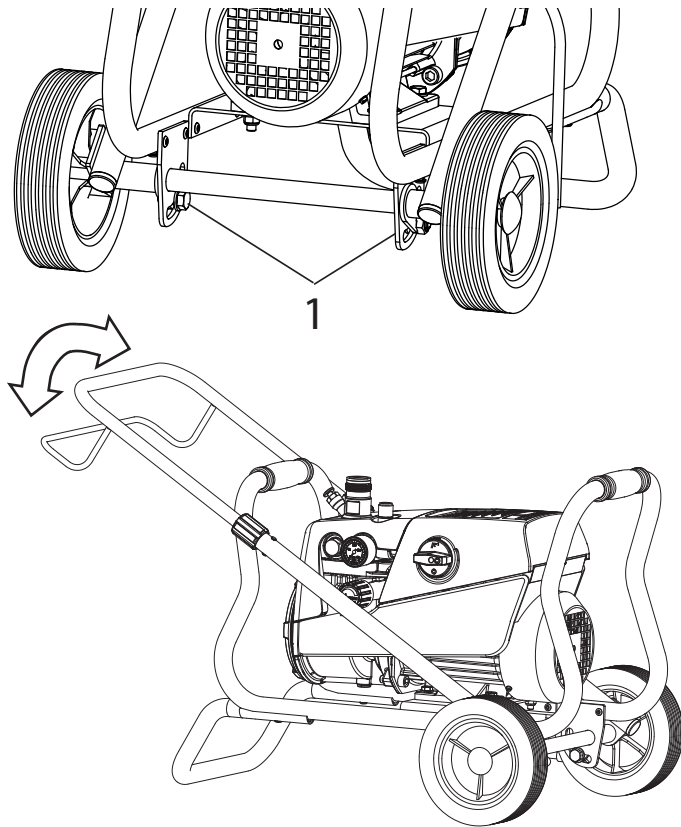

3.6 TECHNICAL DATA

Voltage :	230 V AC, 50 Hz
Fuses :	16 A time-lag
Unit connecting line :	6 m long, 3 x 1.5 mm ²
Max. current consumption:	7.4 A
Degree of protection :	IP 44
Rated input of device:	1.3 kW
Max. operating pressure :	25 MPa (250 bar)
Max. volume flow :	2.6 l/min
Volume flow at 12 MPa (120 bar) with water :	2.3 l/min
Max. temperature of the coating material :	43 °C
Max. viscosity :	20,000 mPas
Empty weight	
Model including carriage:	29 kg
Model on frame:	24 kg
Hydraulic oil filling quantity :	
Hydraulics housing	0.88 liter
Gears	0.05 liter
Plug connection on device (not included in all models):	230 Volt ~, 50 Hz
max. connection:	1500 W
Max. vibration at the spraygun :	lower than 2.5 m/s ²
Max. sound pressure level:	74 dB (A)*

*Place of measurement: 1 m distance from unit and 1.60 m above floor, 12 MPa (120 bar) operating pressure, reverberant floor

4 STARTUP

4.1 UNIT WITH SUCTION SYSTEM

1. Ensure that the sealing surfaces of the connections are clean.
Ensure that the red inlet (1) is inserted in the coating material inlet (4).
2. Use the enclosed 41 mm wrench to screw the union nut (2) at the suction hose (3) onto the coating material inlet (4) and tighten it.
3. Screw the union nut (5) at the return hose (6) to the connection (7) (22mm).

4.2 UNIT WITH UPPER HOPPER (5 LITRES)

1. Ensure that the sealing surfaces of the connections are clean. Ensure that the red inlet (1) is inserted in the coating material inlet (4).
2. Screw the union nut (5) on the return pipe (6) onto the connection (7).
3. Screw the upper hopper (8) onto the coating material inlet (4).

if using hopper with cleaning ring (TopClean) step 4 and 5

4. Fix TopClean on hopper upside
5. Plug in return pipe into TopClean and screw on union nut

4.3 HIGH PRESSURE HOSE AND SPRAY GUN

1. Screw the high pressure hose (9) onto the hose connection
2. Screw the spray gun (10) onto the high pressure hose
3. Tighten all union nuts on high pressure hose so that no coating material can escape.
4. Screw the tip holder with the selected tip onto the spray gun, align tip and tighten union nut.



Attention

When unscrewing the high pressure hose, hold firmly on the hose connection with a 22mm wrench.

4.4 CONNECTION TO THE MAINS NETWORK



Attention

Connection must always be carried out via an appropriately grounded safety outlet with residual-current-operated circuit-breaker.

Before connecting the unit to the mains supply, ensure that the line voltage matches that specified on the unit's rating plate.

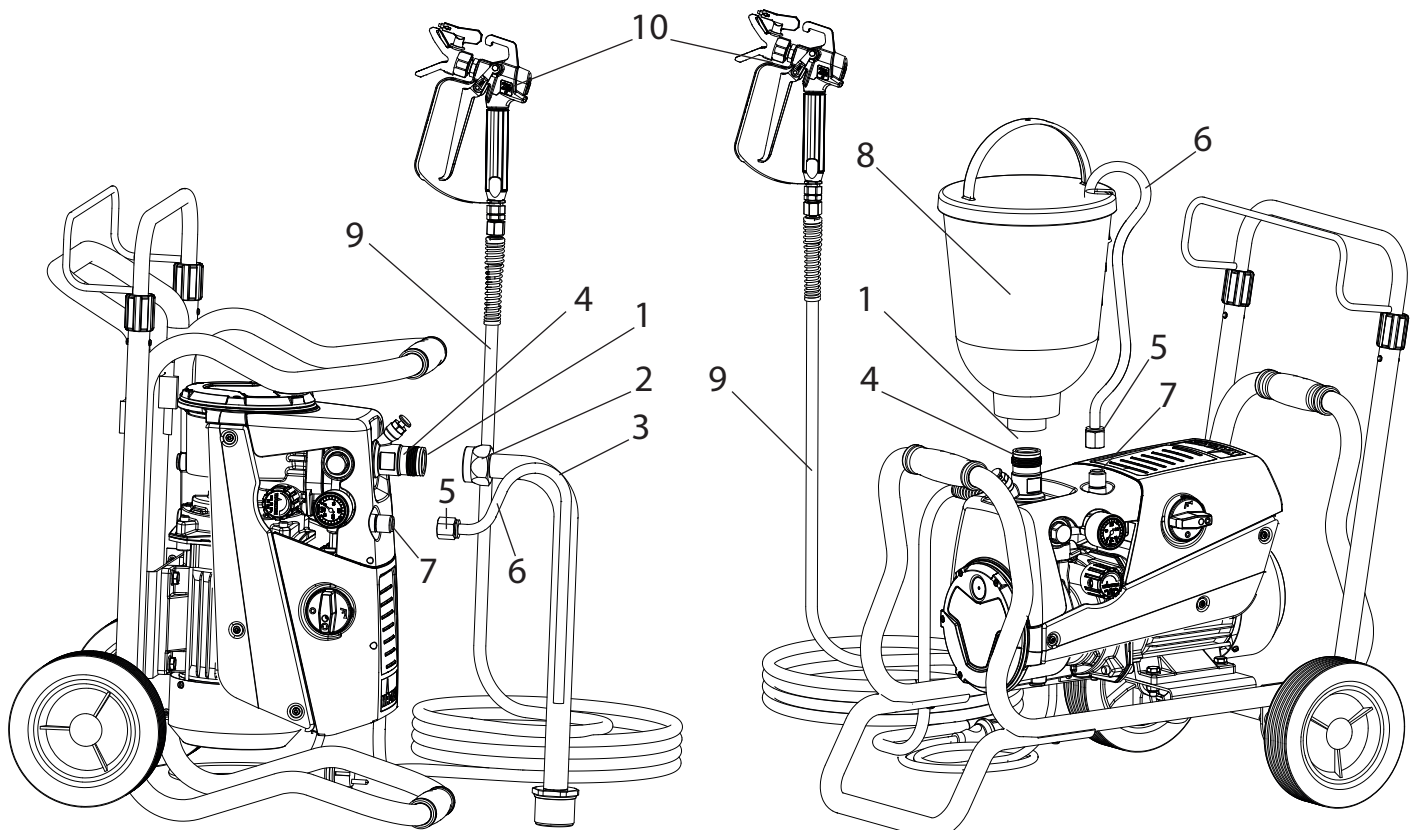

4.5 SOCKET ON UNIT (NOT INCLUDED IN ALL MODELS)

It is possible, for example, to connect an agitator, a working lamp etc with a **maximum of 1500 Watt**.



 <p>Attention</p>	<p>Always switch on the Super Finish 23 PLUS unit first and then the connected unit. Otherwise the fuse protection of 16 A inside the unit will react.</p>
---	--

4.6 CLEANING PRESERVING AGENT WHEN STARTING-UP OF OPERATION INITIALLY

Unit with suction tube

1. Immerse the suction system into a container filled with a suitable cleaning agent (recommendation: water).

Unit with hopper

2. Fill up hopper with a suitable cleaning agent (recommendation: water).
3. Set multifunction switch (1) to  (ON- circulation); the unit commences to run.
4. Turn the pressure regulating knob (2) to the **right** until the stop is reached.
5. Wait until cleaning agent is emitted from the return hose.
6. Turn the pressure regulating knob (2) back approx. one rotation.
7. Set multifunction switch (1) to  (spray). Pressure is rising up inside the high pressure hose (visible at pressure gauge)
8. Point the tip of the spray gun into an open collecting container and pull the trigger guard at the spray gun.
9. The pressure is increased by turning the pressure regulating knob (2) to the right. Set approx. 10 MPa (100 bar) at the pressure gauge.
10. Spray the cleaning agent out of the unit for approx. 1 - 2 min. (~5 litres) into the open collecting container.

4.7 VENTILATE UNIT (HYDRAULIC SYSTEM) IF THE SOUND OF INLET VALVE IS NOT AUDIBLE

1. Switch on the unit.
2. Turn pressure regulating knob (2) **three revolutions** to the **left**.
3. Set multifunction switch (1) to  (ON - circulation). The hydraulic system is ventilated. Leave the unit on for two to three minutes.
4. Then turn pressure regulating knob (2) to the **right** until stop.
5. Press inlet valve pusher (4). Sound of the inlet valve is audible.
6. If not, repeat points 2 and 4

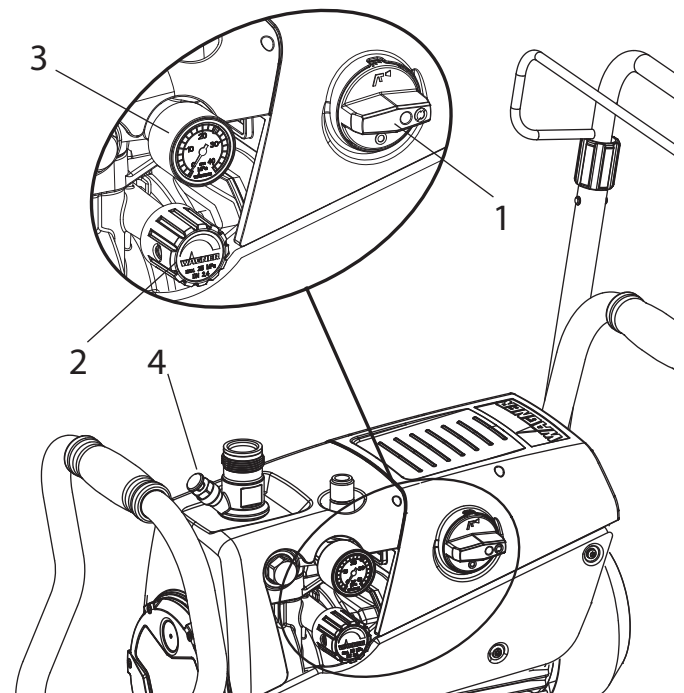



4.8 TAKING THE UNIT INTO OPERATION WITH COATING MATERIAL

Unit with suction tube

1. Immerse the suction system into a container filled with coating material.

Unit with hopper

2. Fill coating material into the hopper.
3. Press inlet valve pusher (4) several times to release possibly clogged inlet valve
4. Set multifunction switch (1) to  (ON - circulation); the unit will start.
5. Turn the pressure regulating knob (2) to the **right** until the stop is reached. When the noise of the valves changes, the unit is bled and takes in coating material.
6. If coating material exits from the return hose, turn the pressure regulating knob (2) back approx. 1 rotation.
7. Set multifunction switch (1) to  (spray). Pressure is rising up inside the high pressure hose (visible at pressure gauge (3)).
8. Pull of the spray gun and spray into an open collecting container in order to remove the remaining cleaning agent from the unit. When coating materials exits from the tip, close the spray gun.
9. Adjust the spraying pressure by turning the pressure regulating knob (2).
10. The unit is ready to spray.

5 SPRAYING TECHNOLOGY

Move the spray gun evenly during the spraying process. If this is not observed, an irregular spraying appearance will be the result. Carry out the movement with the arm, not with the wrist. A parallel distance of approx. 30 cm between the tip and the surface to be coated should always be observed. The lateral limitation of the spray fan should not be too distinct. The edge of spraying should be gradual to facilitate overlapping of the next coat. The spray gun should always be held at an angle of 90° to the surface to be coated. A spray fan aimed obliquely at the surface to be coated leads to an unwanted spray cloud.

To achieve perfect surfaces at varnishing works, special accessories are available at Wagner, e.g. FineFinish tips or an AirCoat gun set. Your Wagner dealer will advise you.

6 HANDLING THE HIGH-PRESSURE HOSE

The unit is equipped with a high-pressure hose specially suited for diaphragm pumps.

 Danger	Danger of injury through leaking high-pressure hose. Replace any damaged high-pressure hose immediately. Never repair defective high-pressure hoses yourself!
---	--

The high-pressure hose is to be handled with care. Avoid sharp bends and folds: the smallest bending radius is about 20 cm. Do **not drive over** the high-pressure hose. Protect against sharp objects and edges.

Never pull on the high-pressure hose to move the device. Make sure that the high-pressure hose cannot twist. This can be avoided by using a Wagner spray gun with a swivel joint and a hose system.

	When using the high-pressure hose while working on scaffolding, it is best to always guide the hose along the outside of the scaffolding.
---	--

	The risk of damage rises with the age of the high-pressure hose. Wagner recommends replacing high-pressure hoses after 6 years.
---	---

	Only use WAGNER original-high-pressure hoses with internal heating in order to ensure functionality, safety and durability.
---	---

7 INTERRUPTION OF WORK

1. Switch off unit, set multifunction switch to  (pressure relief, circulation), then to **0** (OFF).
2. Pull trigger guard of spray gun to decrease the pressure of the high pressure hose and the spray gun.
3. Secure the spray gun, refer to the operating manual of the spray gun.
4. Remove tip from tip holder and store the tip in a small vessel with suitable cleaning agent.
5. Leave the suction system immersed in the coating material or immerse it in the corresponding cleaning agent. The suction filter and unit should not dry out.
6. Cover the material container in order to prevent the paint from drying.

	In using quick-drying or two-component coating materials, do not fail to rinse unit through with a suitable cleaning agent during the processing period.
---	--

8 CLEANING THE UNIT

A clean state is the best method of ensuring operation without problems. After you have finished spraying, clean the unit. Under no circumstances may coating material rests dry and harden in the unit. The cleaning agent used for cleaning (only with a flash point above 21 °C) must be suitable for the coating material used.

- **Secure the spray gun**, refer to the operating manual of the spray gun.
Remove and clean the tip.
- **Unit with suction system**
 1. Set multifunction switch to (ON - circulation).
 2. Remove suction tube from the material container, the return tube remains over the material container.
 3. Immerse the suction system into a container filled with a suitable cleaning agent
 4. Turn the pressure control valve back in order to set a minimal spraying pressure.
 5. Set multifunction switch to (spray).
 6. Pull the trigger guard of the spray gun in order to pump the remaining coating material from the suction hose, high-pressure hose and the spray gun into an open container (if appropriate, increase the pressure at the pressure control valve slowly in order to obtain a higher material flow).

 Attention	The container must be earthed in case of coating materials which contain solvents.
----------------------	--

 Attention	Caution! Do not pump or spray in container with small opening (bunghole)! See safety regulations.
----------------------	--

7. Set multifunction switch to (ON - circulation).
8. Pump suitable cleaning agent in the circuit for several minutes.

	The cleaning effect is increased by alternatively opening and closing the spray gun.
--	--

9. Set multifunction switch to (spray).
10. Pump the remaining cleaning agent into an open container until the pump is empty.
11. Switch off the unit

	Warm water improves the cleaning effect in the case of water-dilutable coating materials.
--	---

- **Unit with upper hopper**
 1. Set multifunction switch to (ON - circulation).
 2. Turn the pressure control valve back in order to set a minimal spraying pressure.
 3. Set multifunction switch to (spray).
 4. Pull the trigger guard of the spray gun in order to pump the remaining coating material from the hopper, high-pressure hose and the spray gun into an open container (if appropriate, increase the pressure at the pressure control valve slowly in order to obtain a higher material flow).

 Attention	The container must be earthed in case of coating materials which contain solvents.
----------------------	--

 Attention	Caution! Do not pump or spray in container with small opening (bunghole)! See safety regulations.
----------------------	--

5. Fill up hopper with suitable cleaning agent.
6. Set multifunction switch to (ON - circulation).
7. Pump suitable cleaning agent in the circuit for several minutes.

with cleaning ring (TopClean) step 8 up to 12



8. Switch reverser knob into a horizontal position.
The cleaning agent will flow around the circumference of the inner hopper wall and will clean it in some minutes, depending of the fouling
9. Switch reverser knob into the upright position.
Cleaning agent is flowing directly into the hopper

	Do not switch the reverser knob at the cleaning ring into the horizontal position when the pump is loaded with coating material. The holes could be plugged. As a result the cleaning function will be reduced, as the cleaning ring has to clean itself first.
--	--

10. Set multifunction switch to (spray).
11. Pump the remaining cleaning agent from the hopper, high-pressure hose and the spray gun into an open container
12. Set multifunction switch to (ON - circulation).
13. Switch off unit

CLEANING THE UNIT

8.1 CLEANING THE UNIT FROM THE OUTSIDE

 Danger	<p>First unplug the power plug from the outlet.</p> <p>Danger of short-circuits caused by water ingress! Never spray down the unit with high-pressure or high-pressure steam cleaners.</p>
 Danger	<p>Do not put the high-pressure hose into solvents. Use only a wet cloth to wipe down the outside of the hose.</p>

Wipe down unit externally with a cloth which has been immersed in a suitable cleaning agent.

8.2 SUCTION FILTER

	<p>Clean filters always ensure maximum volume, constant spray pressure and problem-free functioning of the unit.</p>
---	--

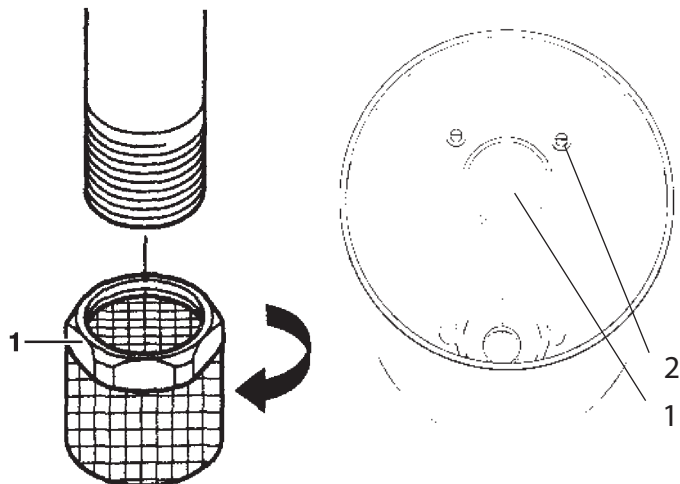
**suction tube****5l hopper**

Unit with suction system

1. Unscrew the filter (Item 1) from the suction tube.
2. Clean or replace the filter.
Carry out cleaning with a hard brush and a corresponding cleaning agent.

Unit with hopper

1. Release screws with a screwdriver (Item 2).
2. Lift and remove filter disk with a screwdriver
3. Clean or replace the filter disk.
Carry out cleaning with a hard brush and a corresponding cleaning agent.

8.3 HIGH-PRESSURE FILTER

1. Switch off unit – set multifunction switch to **0** (OFF).
2. Open the high-pressure filter and clean the filter insert. To do so:
3. Unscrew the filter housing (1) by hand.
4. Remove the filter insert (2) and pull out the bearing spring (3).
5. Clean all the parts with the corresponding cleaning agent. If compressed air is available – blow through the filter insert and bearing spring.
6. When mounting the filter ensure that the bearing ring (4) in the filter insert is positioned correctly and check the O-ring at the filter housing for damage.
7. Screw on the filter housing by hand until it stops (a higher tightening force only impedes later dismantling).

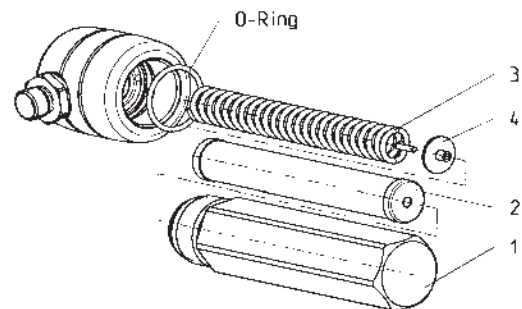

8.4 CLEANING THE AIRLESS SPRAY GUN

1. Rinse the Airless spray gun with a suitable cleaning agent under lower operating pressure.
2. Clean the tip thoroughly with a suitable cleaning agent so that no suitable coating material rests remain.
3. Do not store the tip in solvent because this reduces the durability considerably.
4. Clean the outside of the Airless spray gun thoroughly.

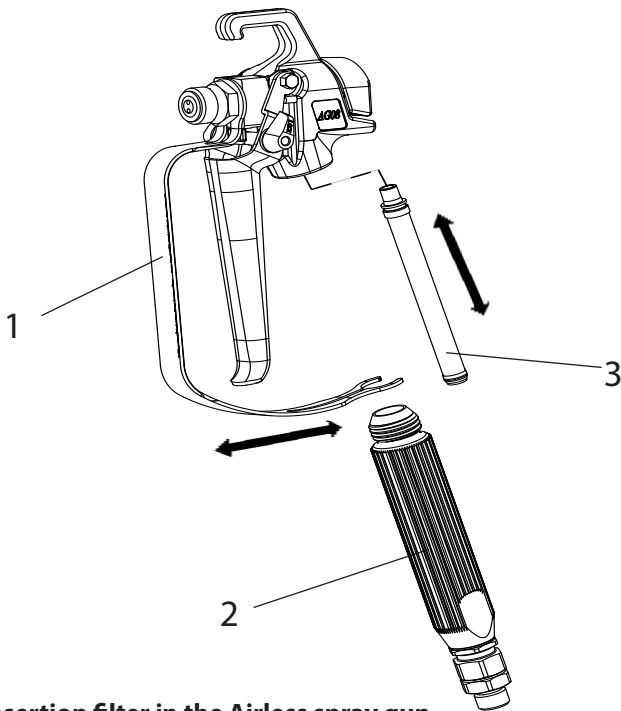

Insertion filter in the Airless spray gun

Removal

1. Pull the protective bracket (1) forwards.
2. Screw the grip (2) out of the gun housing. Pull out the insertion filter (3).
3. If the insertion filter is clogged or defective, replace it.

Installation

1. Slide the insertion filter (3) with the longer cone into the gun housing.
2. Screw the grip (2) into the gun housing and tighten it.
3. Latch in the protective bracket (1).

9 SERVICING

9.1 GENERAL SERVICING



We strongly recommend having an annual check carried out by technicians for safety reasons. Please observe all the applicable national regulations.



You can servicing of the unit carried out by the Wagner Service. Favourable conditions can be agreed with a service agreement and/or maintenance packages.

Minimum check before every startup:

1. Check the high-pressure hose, spray gun with rotary joint, power supply cable with plug for damage.
2. Check whether the pressure gauge can be read.

Check at periodical intervals:

1. Check inlet and outlet valve according wear. Clean it and replace worn out parts.
2. Check all filter inserts (spray gun, suction system) clean it and replace if necessary.

9.2 HIGH-PRESSURE HOSE

Inspect the high-pressure hose visually for any notches or bulges, in particular at the transition in the fittings. It must be possible to turn the union nuts freely. A conductivity of less than

1 MΩ must exist across the entire length.



Have all the electric tests carried by the Wagner Service.



The risk of damage rises with the age of the high-pressure hose. Wagner recommends replacing high-pressure hoses after 6 years.

10 REPAIRS AT THE UNIT



Switch the unit off.
Before all repair work: Unplug the power plug from the outlet.

10.1 INLET VALVE PUSHER

1. Use a 17 mm spanner to screw out the inlet valve button.
2. Replace the wiper (1) and O-ring (2).

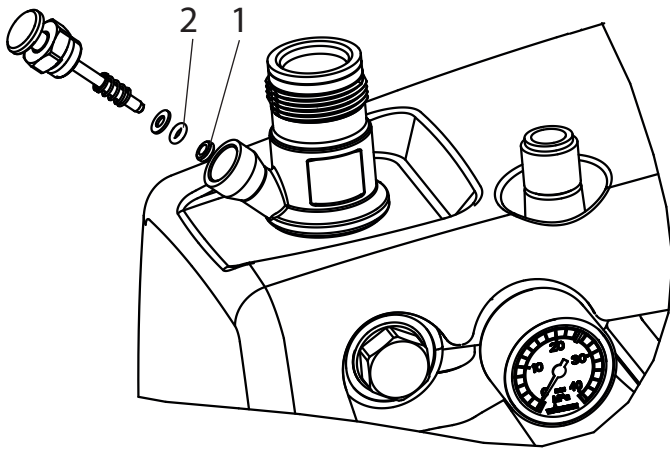

10.2 INLET VALVE

1. Place the enclosed 30 mm wrench on the trigger housing (1).
2. Loosen the trigger housing (1) with light blows of a hammer on the end of the wrench.
3. Screw out the trigger housing with the inlet valve (2) from the paint section.
4. Pull of the clasp (3) using the enclosed screwdriver.
5. Place the enclosed 30 mm wrench on the inlet valve (2). Turn out the inlet valve carefully.
6. Clean the valve seat (4) with a cleaning agent and brush (ensure that no brush hairs are left behind).
7. Clean the seals (5, 6) and check for damage. Replace, if necessary.
8. Check all the valve parts for damage. In case of visible wear replace the inlet valve.

Installation

1. Insert the inlet valve (2) into the trigger housing (1) and secure with the clasp (3). Ensure that the (black) seal (5) is mounted in the trigger housing.
2. Screw the unit from the trigger housing and the inlet valve into the paint section. The same (black) seal (6) has to be mounted in the paint section.
3. Tighten the trigger housing with the 30 mm wrench and tighten with three light blows of the hammer on the end of the wrench. (Corresponds to approx. 90 Nm tightening torque).

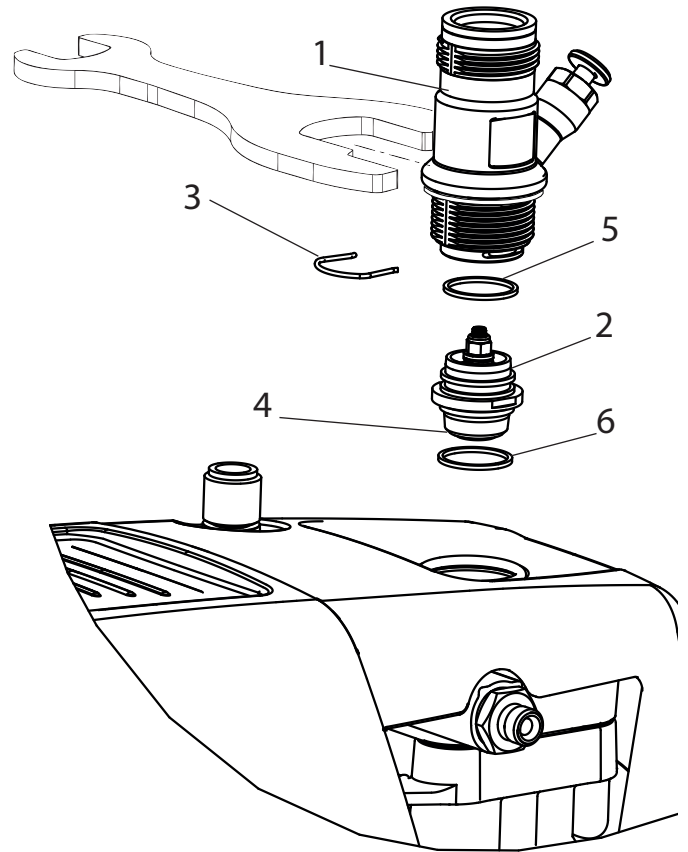

10.3 OUTLET VALVE

1. Use a 22 mm wrench to screw the outlet valve from the paint section.
2. Carefully pull of the clasp (1) using the enclosed screwdriver. The compression spring (2) presses ball (4) and valve seat (5) out.
3. Clean or replace the components.
4. Check the O-ring (7) for damage.
5. Check the installation position when mounting the spring support ring (3) (clipped onto spring (2)), outlet valve seat (5) and seal (6), refer to figure.

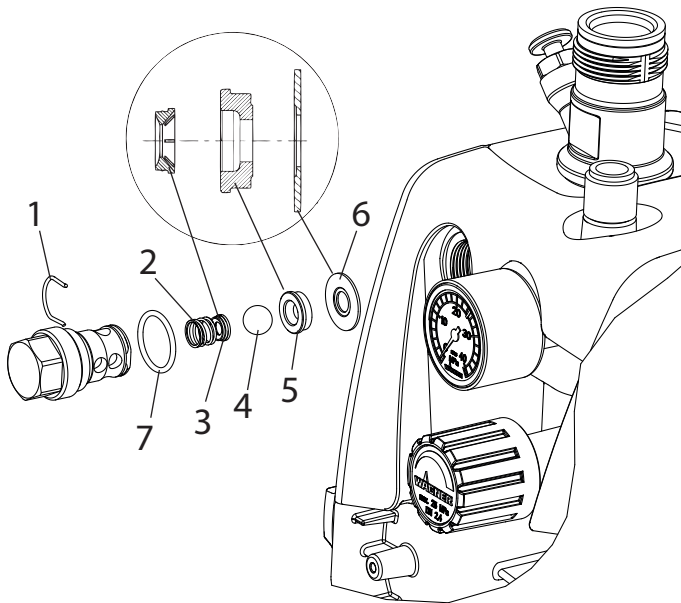

10.4 PRESSURE CONTROL VALVE



Only have the pressure control valve (1) replaced by the customer service. The max. operating pressure has to be reset by the customer service.

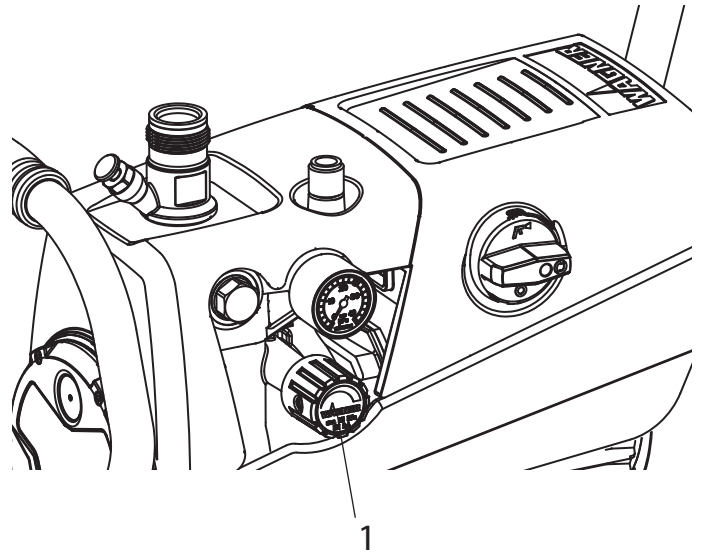

10.5 REPLACING THE POWER CABLE



Danger

This may only be carried out by a skilled electrician. No liability is assumed for incorrect installation.

Switch the unit off.

Before all repair work: Unplug the power plug from the outlet.

1. In models with a front cover unscrew the trigger housing with inlet valve (1) from the paint section (see inlet valve, 10.2, sections 1 to 3) and remove the front cover (2) by unscrewing the screws.
2. Remove the multi-function switch (3) by unscrewing the screws.
3. Remove the rear cover (4) by loosening the screws.
4. Loosen the cable threaded joint (5).
5. Loosen the wires in the mains terminal (6).
6. Replace the unit connecting line.
(only an approved power cable with the designation H07-RNF with a splash-proof plug may be used).
7. Connect the green/yellow wire to the contact with the PE sign.
8. Remount the covers carefully (do not squeeze any cables!)
9. Screw the trigger housing back into place (see inlet valve, 10.2, sections 3)

10.6 TYPICAL WEAR PARTS

Despite the use of high-quality materials the highly abrasive effect of the paints means that wear can occur at the following parts:

Inlet valve (spare part Order No.: 0344700)

For replacing refer to Section 10.2

(failure becomes noticeable through performance loss and/or poor or no suction)

Outlet valve (spare part Order No.: 0341702)

For replacing refer to Section 10.3

(failure becomes noticeable through performance loss and/or poor suction) The outlet valve is usually considerably more durable than the inlet valve. Thorough cleaning may already help here.

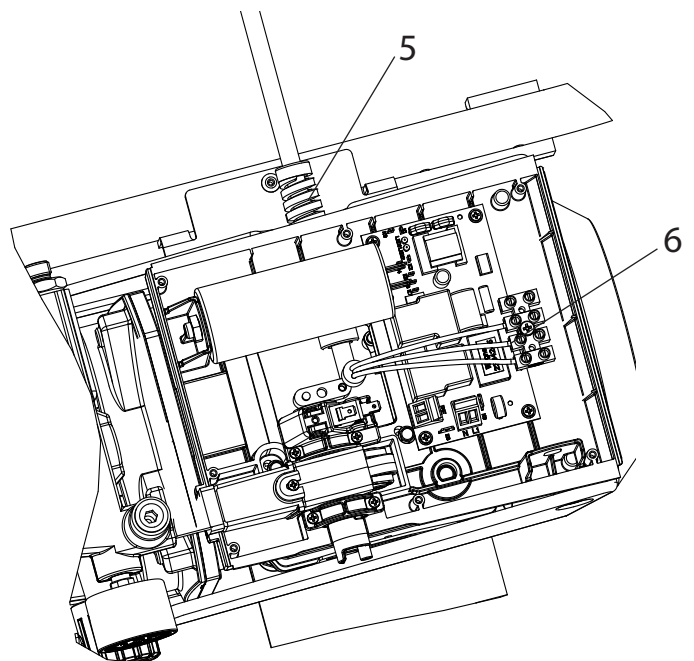
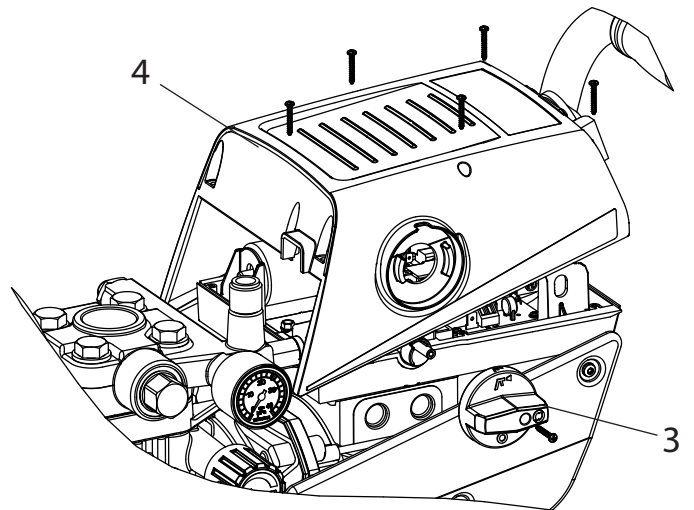
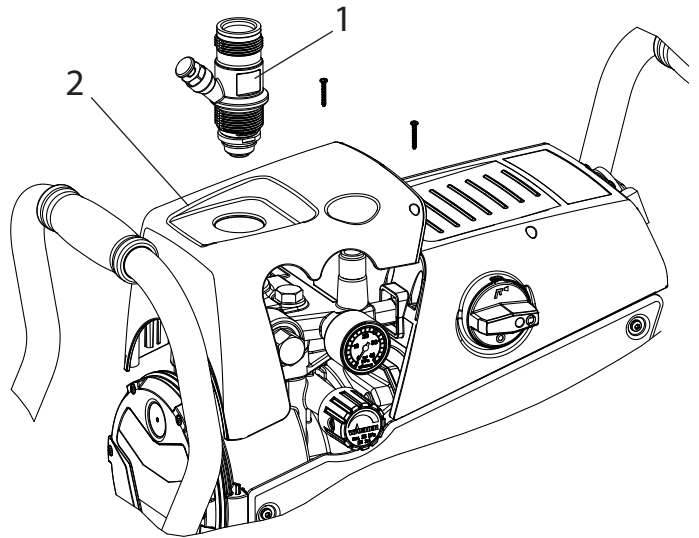

10.7 CONNECTION DIAGRAM

A) SUPER FINISH 23 PLUS WITH SOCKET

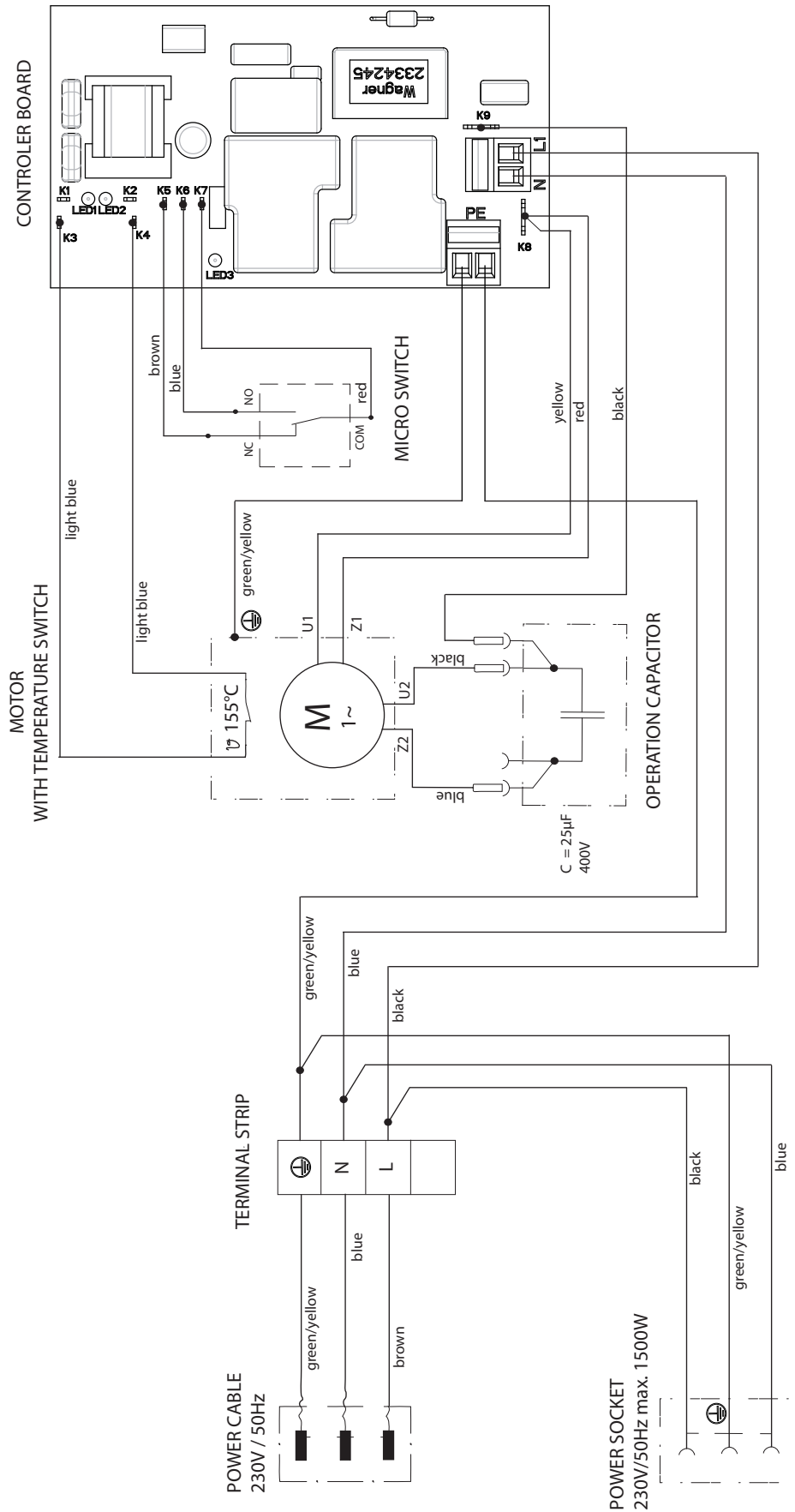

B) SUPER FINISH 23 PLUS

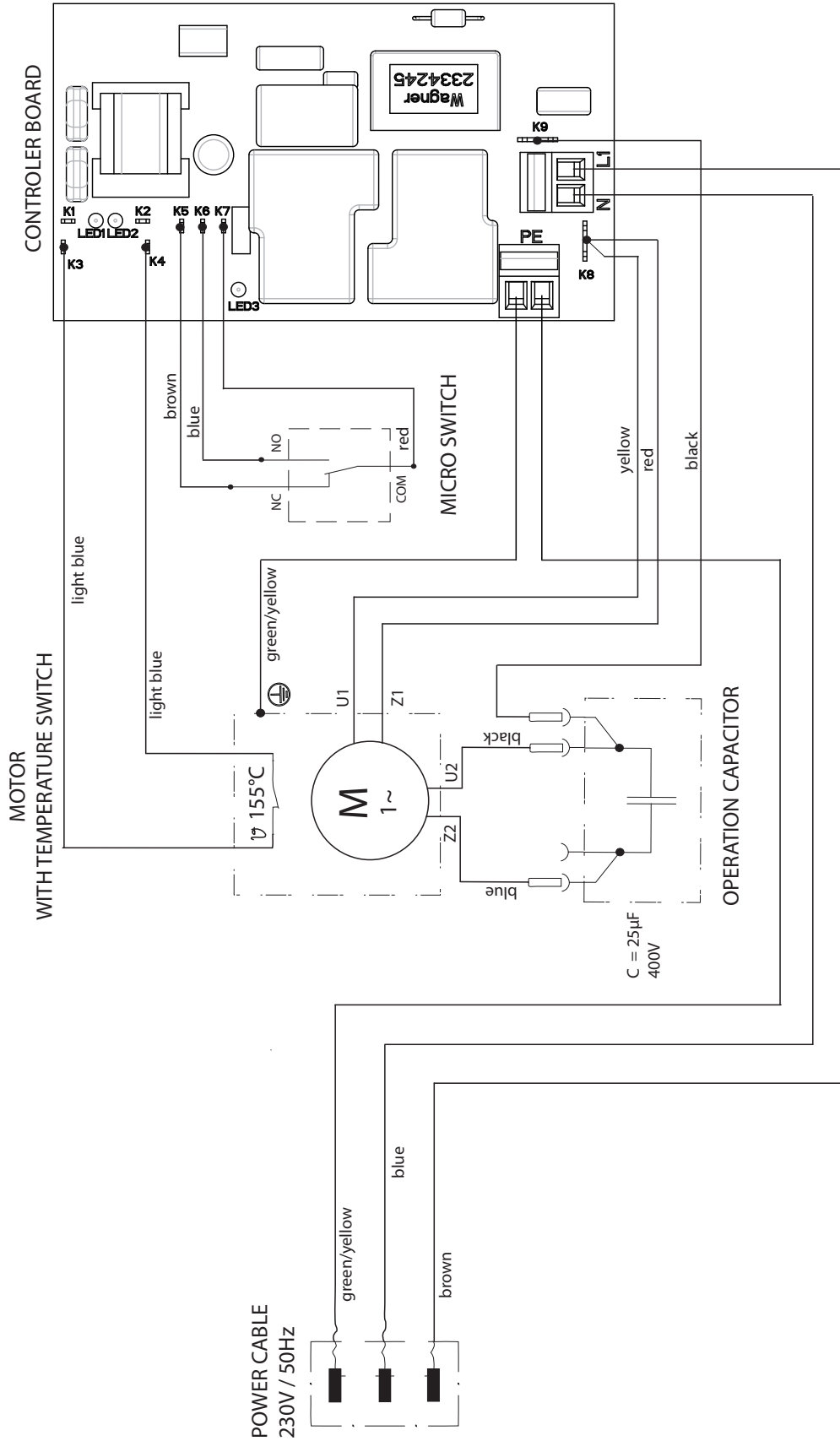

10.8 REMEDY IN CASE OF FAULTS

TYPE OF MALFUNCTION	WHAT ELSE?	POSSIBLE CAUSE	MEASURES FOR ELIMINATING THE MALFUNCTION
Unit does not start	Multifunction switch can not switched on	No voltage applied	Check voltage supply
		Unit fuse has triggered	Let the motor cool down
		Multi-function switch not set back previously to „0“	Set multi-function switch to „0“ and then switch back on
Unit does not suck in	Air bubbles do not exit at the return hose	Inlet valve clogged	Press the inlet valve button until the stop is reached several times by hand
		Inlet/outlet valve soiled / foreign bodies (e.g. threads) drawn in / worn	Remove the valves and clean then (-> refer to Section Pkt.10.2/10.3) / replace worn parts
		Pressure control valve turned down completely	Turn the pressure control valve to the right until the stop is reached
	Air bubbles exit from the return hose	Unit is sucking in outside air	Check: Suction system tightened properly? Cleaning connection (if available) at rigid suction tube screwed tight and not leaking? Inlet valve button leaky? -> Replace wiper and O-ring (-> refer to Section 10.1) The red entry is missing in the coating material entrance (-> see 4.1)
Unit does not generate pressure	Unit has sucked in	Air in the oil circuit	Bleed the oil circuit in the unit by turning the pressure control valve completely to the left (until overturning) and let it run approx. 2 – 3 min. Then turn the pressure control valve to the right and set the spraying pressure (repeat process several times, if necessary). Process is assisted by positioning the unit vertically.
	Unit reached pressure, but the pressure collapses, also at the pressure gage, during spraying.	Suction filter clogged	Check the suction filter. If necessary, clean/replace
		Paint cannot be worked in this state. Due to its properties the paint clogs the valves (inlet valve) and the delivery rate is too low.	Dilute the paint
	Unit reached pressure, but the pressure collapses during spraying. pressure gage still shows high pressure	Clogged filter do not let enough paint pass	Check/clean the (high-pressure filter) gun filter
		Tip clogged	Clean the tip (-> refer to Section 10.1)
	Unit does not generate the max. pressure possible. Paint nevertheless exits at the return hose.	Relief valve defective	Please contact Wager Customer Service

11 SPARE PARTS AND ACCESSORIES

11.1 SUPER FINISH 23 PLUS ACCESSORIES

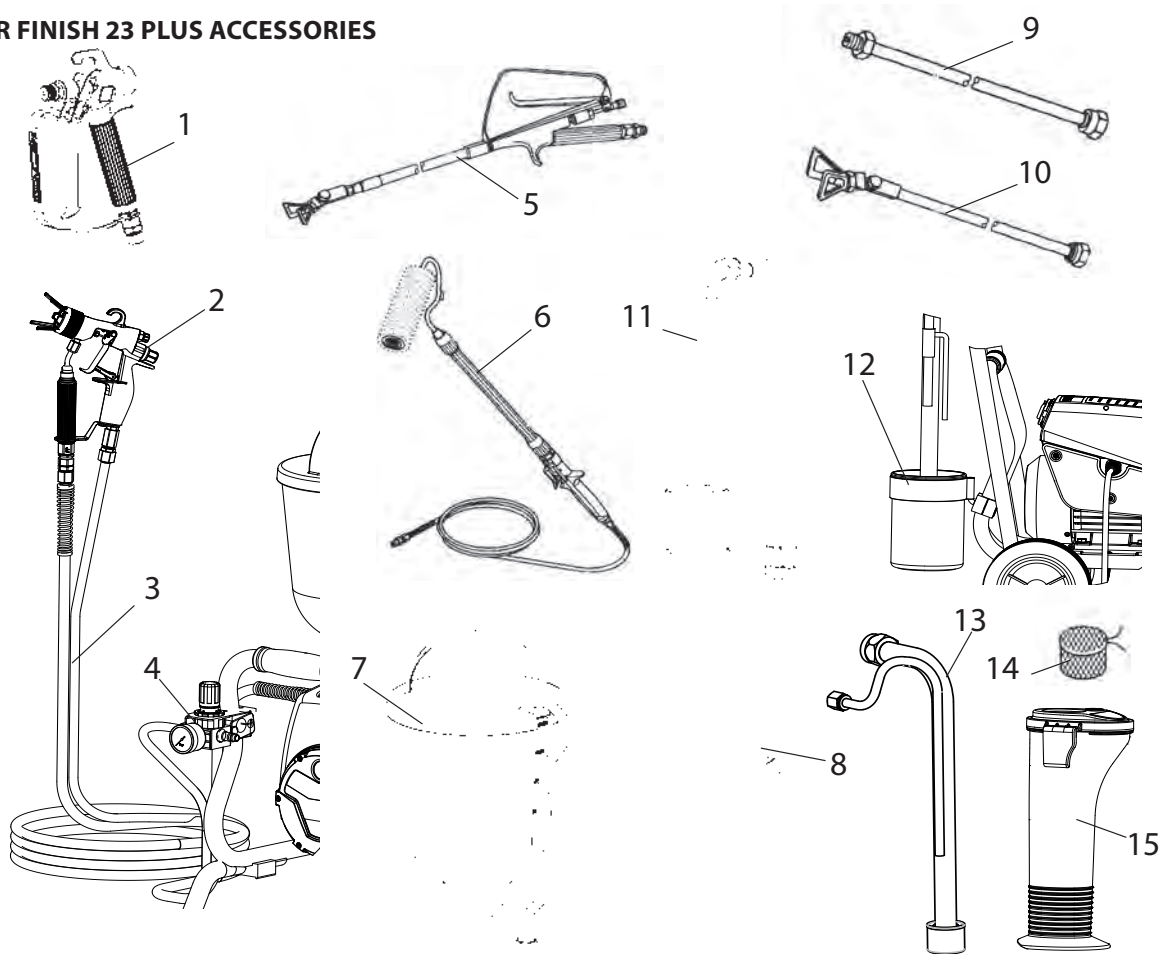

Accessories:

ITEM	DESIGNATION	ORDER NO.
1	Spray gun AG-14 (stainless steel)	0502 166
	Spray gun AG-08 (aluminium made)	0296 388
2	AirCoat spray gun AC 4600 (blue)	0394 156
3	Double hose	9984 564
	HP hose DN-3, 7.5 m	9984 583
4	AirCoat-controler set	0340 250
5	Pole gun Length 120cm; G thread 7/8"	0296 441
	Length 120cm; F thread 11/16"	0296 443
	Length 200cm; G thread 7/8"	0296 442
	Length 200cm; F thread 11/16	0296 444
6	Inline Roller	0345 010
7	Hopper 5l	0341 265
8	Hopper cleaning ring (TopClean)	0340 930

ITEM.	DESIGNATION	ORDER NO.
9	Tip extension Length 15 cm	0556 051
	Length 30 cm	0556 052
	Length 45 cm	0556 053
	Length 60 cm	0556 054
10	Tip extension with Sleuable knee joint Length 100 cm	0096 015
	Length 200 cm	0096 016
	Length 300 cm	0096 017
11	Suction system (flexible) for dispersionen	0034 630
12	Cleaning container for suction system with holder (only for flexible suction system)	2343 481
13	Suction system (rigid) for dispersions	2342 879
14	Filter bag, mesh width 0,3 mm	0097 531
15	PumpRunner (only for static suction system)	2306 987



Airless tip table

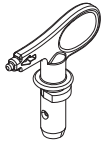

Wagner TradeTip 3 tip
up to 270 bar
(27 MPa)



without tip
F thread (11/16 - 16 UN)
for Wagner spray guns
Order no. 0289391

without tip
G thread (7/8 - 14 UN)
for Graco/Titan spray guns
Order no. 0289390



All of the tips in the table below are supplied together with the appropriate gun filter.

Application	Tip marking	Spray angle	Bore inch / mm	Spraying width mm 1)	Gun filter	Order no.
Water-thinnable and solvent-based paints and varnishes, oils, separating agents	107	10°	0.007 / 0.18	100	red	0553107
	207	20°	0.007 / 0.18	120	red	0553207
	307	30°	0.007 / 0.18	150	red	0553307
	407	40°	0.007 / 0.18	190	red	0553407
	109	10°	0.009 / 0.23	100	red	0553109
	209	20°	0.009 / 0.23	120	red	0553209
	309	30°	0.009 / 0.23	150	red	0553309
	409	40°	0.009 / 0.23	190	red	0553409
	509	50°	0.009 / 0.23	225	red	0553509
	609	60°	0.009 / 0.23	270	red	0553609
Synthetic-resin paints PVC paints	111	10°	0.011 / 0.28	100	red	0553111
	211	20°	0.011 / 0.28	120	red	0553211
	311	30°	0.011 / 0.28	150	red	0553311
	411	40°	0.011 / 0.28	190	red	0553411
	511	50°	0.011 / 0.28	225	red	0553511
	611	60°	0.011 / 0.28	270	red	0553611
Paints, primers Fillers	113	10°	0.013 / 0.33	100	red	0553113
	213	20°	0.013 / 0.33	120	red	0553213
	313	30°	0.013 / 0.33	150	red	0553313
	413	40°	0.013 / 0.33	190	red	0553413
	513	50°	0.013 / 0.33	225	red	0553513
	613	60°	0.013 / 0.33	270	red	0553613
	813	80°	0.013 / 0.33	330	red	0553813
	Fillers Rust protection paints	115	10°	0.015 / 0.38	100	yellow
215		20°	0.015 / 0.38	120	yellow	0553215
315		30°	0.015 / 0.38	150	yellow	0553315
415		40°	0.015 / 0.38	190	yellow	0553415
515		50°	0.015 / 0.38	225	yellow	0553515
615		60°	0.015 / 0.38	270	yellow	0553615
715		70°	0.015 / 0.38	300	yellow	0553715
815		80°	0.015 / 0.38	330	yellow	0553815
Rust protection paints Latex paints Dispersions		117	10°	0.017 / 0.43	100	yellow
	217	20°	0.017 / 0.43	120	yellow	0553217
	317	30°	0.017 / 0.43	150	yellow	0553317
	417	40°	0.017 / 0.43	190	yellow	0553417
	517	50°	0.017 / 0.43	225	yellow	0553517
	617	60°	0.017 / 0.43	270	yellow	0553617
	717	70°	0.017 / 0.43	300	yellow	0553717
	817	80°	0.017 / 0.43	330	yellow	0553817
	Rust protection paints Latex paints Dispersions	219	20°	0.019 / 0.48	120	white
319		30°	0.019 / 0.48	150	white	0553319
419		40°	0.019 / 0.48	190	white	0553419
519		50°	0.019 / 0.48	225	white	0553519
619		60°	0.019 / 0.48	270	white	0553619
719		70°	0.019 / 0.48	300	white	0553719
819		80°	0.019 / 0.48	330	white	0553819
919		90°	0.019 / 0.48	385	white	0553919
Flame retardant		221	20°	0.021 / 0.53	120	white
	321	30°	0.021 / 0.53	150	white	0553321
	421	40°	0.021 / 0.53	190	white	0553421
	521	50°	0.021 / 0.53	225	white	0553521
	621	60°	0.021 / 0.53	270	white	0553621
	721	70°	0.021 / 0.53	300	white	0553721
	821	80°	0.021 / 0.53	330	white	0553821

1) Spray width at about 30 cm to the object and 100 bar (10 MPa) pressure with synthetic-resin paint 20 DIN seconds.



All of the tips in the table below are supplied together with the appropriate gun filter.

Application	Tip marking	Spray angle	Bore inch / mm	Spraying width mm 1)	Gun filter	Order no.
Roof coatings	223	20°	0.023 / 0.58	120	white	0553223
	323	30°	0.023 / 0.58	150	white	0553323
	423	40°	0.023 / 0.58	190	white	0553423
	523	50°	0.023 / 0.58	225	white	0553523
	623	60°	0.023 / 0.58	270	white	0553623
	723	70°	0.023 / 0.58	300	white	0553723
	823	80°	0.023 / 0.58	330	white	0553823
	Thick-film materials, Corrosion protection Spray filler	225	20°	0.025 / 0.64	120	white
325		30°	0.025 / 0.64	150	white	0553325
425		40°	0.025 / 0.64	190	white	0553425
525		50°	0.025 / 0.64	225	white	0553525
625		60°	0.025 / 0.64	270	white	0553625
725		70°	0.025 / 0.64	300	white	0553725
825		80°	0.025 / 0.64	330	white	0553825
227		20°	0.027 / 0.69	120	white	0553227
327		30°	0.027 / 0.69	150	white	0553327
427		40°	0.027 / 0.69	190	white	0553427
527		50°	0.027 / 0.69	225	white	0553527
627		60°	0.027 / 0.69	270	white	0553627
827		80°	0.027 / 0.69	330	white	0553827
229		20°	0.029 / 0.75	120	white	0553229
329		30°	0.029 / 0.75	150	white	0553329
429		40°	0.029 / 0.75	190	white	0553429
529		50°	0.029 / 0.75	225	white	0553529
629		60°	0.029 / 0.75	270	white	0553629
231		20°	0.031 / 0.79	120	white	0553231
331		30°	0.031 / 0.79	150	white	0553331
431		40°	0.031 / 0.79	190	white	0553431
531		50°	0.031 / 0.79	225	white	0553531
631		60°	0.031 / 0.79	270	white	0553631
731		70°	0.031 / 0.79	300	white	0553731
831		80°	0.031 / 0.79	330	white	0553831
233		20°	0.033 / 0.83	120	white	0553233
333		30°	0.033 / 0.83	150	white	0553333
433		40°	0.033 / 0.83	190	white	0553433
533		50°	0.033 / 0.83	225	white	0553533
633		60°	0.033 / 0.83	270	white	0553633
235		20°	0.035 / 0.90	120	white	0553235
335		30°	0.035 / 0.90	150	white	0553335
435		40°	0.035 / 0.90	190	white	0553435
535		50°	0.035 / 0.90	225	white	0553535
635		60°	0.035 / 0.90	270	white	0553635
735		70°	0.035 / 0.90	300	white	0553735
439		40°	0.039 / 0.99	190	white	0553439
539		50°	0.039 / 0.99	225	white	0553539
639		60°	0.039 / 0.99	270	white	0553639
Heavy duty applications		243	20°	0.043 / 1.10	120	green
	443	40°	0.043 / 1.10	190	green	0553443
	543	50°	0.043 / 1.10	225	green	0553543
	643	60°	0.043 / 1.10	270	green	0553643
	445	40°	0.045 / 1.14	190	green	0553445
	545	50°	0.045 / 1.14	225	green	0553545
	645	60°	0.045 / 1.14	270	green	0553645
	451	40°	0.051 / 1.30	190	green	0553451
	551	50°	0.051 / 1.30	225	green	0553551
	651	60°	0.051 / 1.30	270	green	0553651
	252	20°	0.052 / 1.32	120	green	0553252
	455	40°	0.055 / 1.40	190	green	0553455
	555	50°	0.055 / 1.40	225	green	0553555
	655	60°	0.055 / 1.40	270	green	0553655
	261	20°	0.061 / 1.55	120	green	0553261
	461	40°	0.061 / 1.55	190	green	0553461
	561	50°	0.061 / 1.55	225	green	0553561
	661	60°	0.061 / 1.55	270	green	0553661
	263	20°	0.063 / 1.60	120	green	0553263
	463	40°	0.063 / 1.60	190	green	0553463
	565	50°	0.065 / 1.65	225	green	0553565
	665	60°	0.065 / 1.65	270	green	0553665
	267	20°	0.067 / 1.70	120	green	0553267
467	40°	0.067 / 1.70	190	green	0553467	

1) Spray width at about 30 cm to the object and 100 bar (10 MPa) pressure with synthetic-resin paint 20 DIN seconds.

2SpeedTip

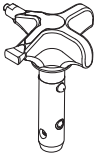

The innovative changeover nozzle from WAGNER combines two nozzle cores into one nozzle.



2 Speed Tip holder
Order no. 0271065

Tip table

Object size	Painting material		
	Lacquer (L)	Emulsion (D)	Filler (S)
Small		D5 Nozzles: 111 / 415 Order no. 0271 062	S5 Nozzles: 225 / 629 Order no. 0271 064
		D7 Nozzles: 113 / 417 Order no. 0271 063	
	L10 Nozzles: 208 / 510 Order no. 0271 042	D10 Nozzles: 111 / 419 Order no. 0271 045	S10 Nozzles: 527 / 235 Order no. 0271 049
Medium	L20 Nozzles: 210 / 512 Order no. 0271 043	D20 Nozzles: 115 / 421 Order no. 0271 046	S20 Nozzles: 539 / 243 Order no. 0271 050
Large	L30 Nozzles: 212 / 514 Order no. 0271 044	D30 Nozzles: 115 / 423 Order no. 0271 047	S30 Nozzles: 543 / 252 Order no. 0271 051
X-Large		D40 Nozzles: 117 / 427 Order no. 0271 048	
Recommended gun filter	red	white	-

11.2 SPARE PARTS LIST SF 23 PLUS

ITEM	ORDER-NO	DESIGNATION
1	0340 339	Inlet
2	2334 383	Inlet valve trigger housing
3	0341 336	Clasp
4	9971 486	O-ring
5	0341 316	Wiper
6	2337 033	Inlet valve trigger (incl. pos. 4, 5)
7	0341 331	Sealing ring
8	0344 700	Inlet valve (incl. pos.7 (2x))
9	2334 402	Inlet valve complete. (pos. 1,2,3,6,8)
10	0421 328	Oval head screw 3, 17x20
11	2337 138	O-ring 31.4 x 3.55
12	9952 685	Cable threaded joint
13	0261 352	Mains cable H07-RNF 3x 1.5mm ² , 6m long
14	0344 336	Double socket NPS 1/4"
15	2334 038	Cover
16	2334 044	Cover (right)
17	2315 382	Oval head screw M4x10
18	2339 570	Label SF 23 PLUS
19	0341 347	Sealing ring
20	0341 327	Outlet valve seat
21	9941 501	Ball 10
22	0253 405	Spring support ring
23	0341 326	Pressure spring
24	0341 328	Clasp
25	9971 470	O-ring 20x2
	0341 702	Outlet valve, service set (pos. 19-25)
26	2342 946	Outlet valve complete (incl. pos.19-25)
27	2334 046	Connecting plate
28	2334 042	Cover (left)
29	2337 557	Fan cover
30	9902 225	Oval head screw 3.5x9.5
31	2341 466	Label (left)
32	9903 348	Self drilling screw
33	2337 484	Connecting plate
34	2342 501	Multi-function switch
35	9950 241	Socket

36	9905 113	Oval head screw 5x10
37	9950 242	Seal
38	2342 535	Label
39	2343 666	Pressure gauge
40	9970 218	Sealing ring
41	2341 465	Label (right)

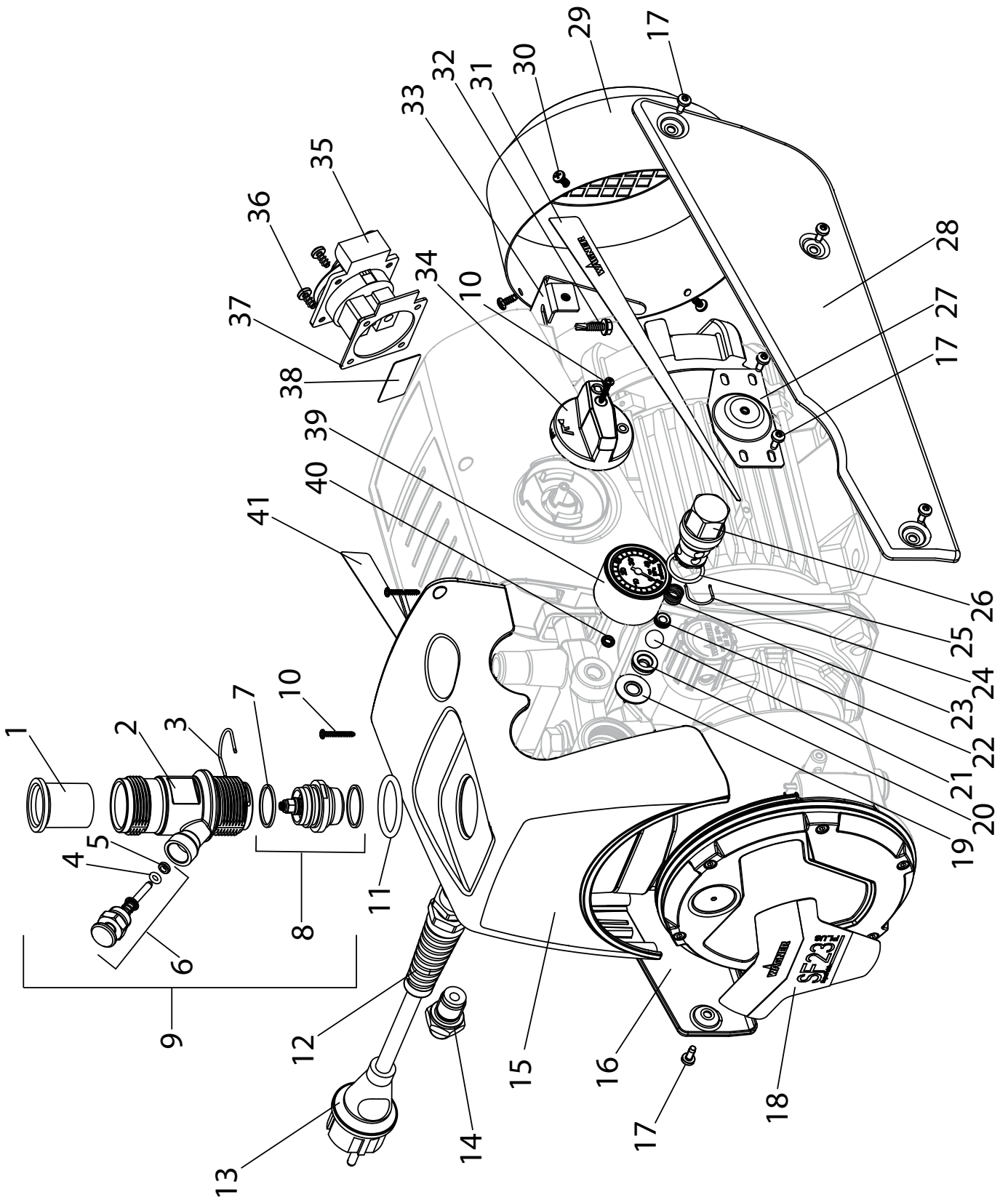

Spare parts diagram SF 23 PLUS

11.3 SPARE PARTS LIST HIGH-PRESSURE FILTER

ITEM	ORDER NO.	DESIGNATION
1	0097 121	High-pressure filter HF- 01 compl.
2	0097 301	Filter block
3	0097 302	Filter housing
4	0097 303	Hollow screw
5	0097 304	Seal ring
6	9970 110	Seal ring
7	9974 027	O-ring 30x2 (PTFE)
8	9971 401	O-ring 16x2 (PTFE)
9	0508 749	Bearing spring
10	0508 603	Bearing ring
11	0508 748	Filter insert 60 meshes
	0508 450	Optional: Filter insert 100 meshes
	0508 449	Filter insert 30 meshes
12	9994 245	Pressure spring

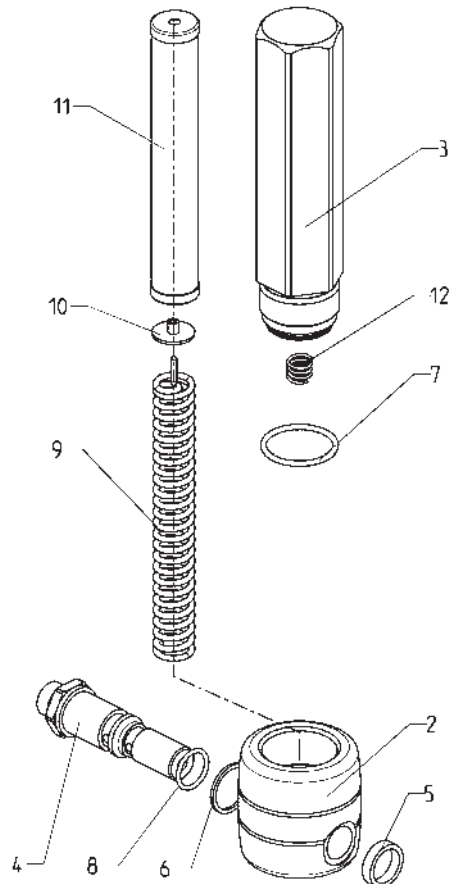

Spare parts diagram high-pressure filter

11.4 SPARE PARTS LIST TROLLEY

ITEM	ORDER NO.	DESIGNATION
1	2343 670	Trolley assy. (SF 23 PLUS)
2	9910 208	Hexagon nut M8
3	9920 102	Washer A 8.4
4	9900 118	Hexagon screw M8x30
5	3054 019	Hexagon screw M10x20
6	9920 106	Washer A 10.5
7	2340 954	Intermediate plate

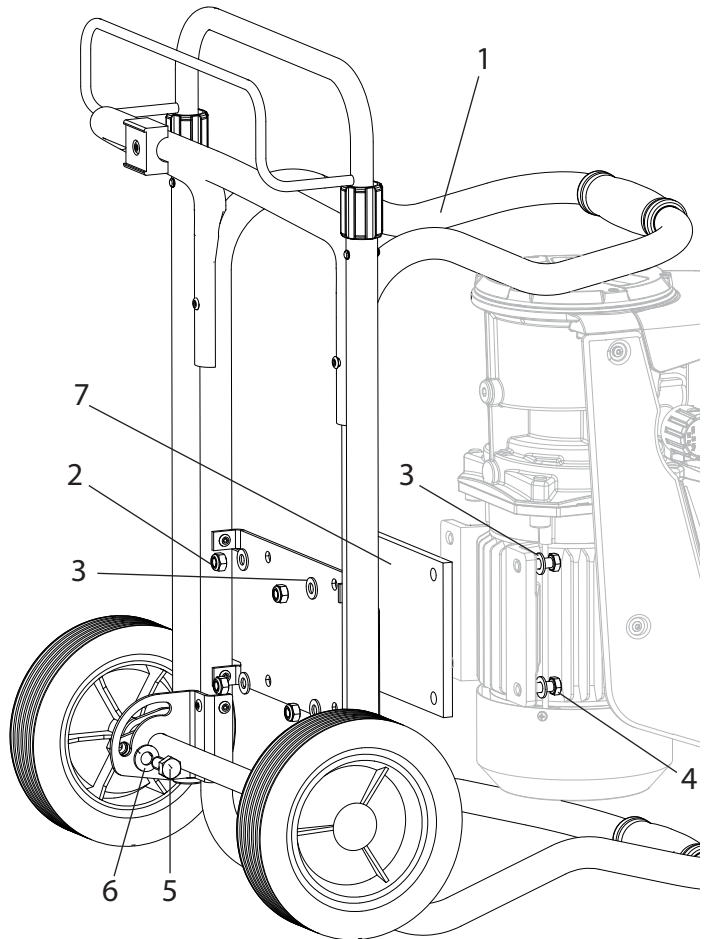

Spare parts diagram trolley SF 23 PLUS

11.5 SPARE PARTS LIST FRAME

ITEM	ORDER NO.	DESIGNATION
1	2343 637	Frame complete
2	9900 118	Hexagon screw M8x30
3	9920 102	Washer A 8.4
4	9910 208	Hexagon nut M8

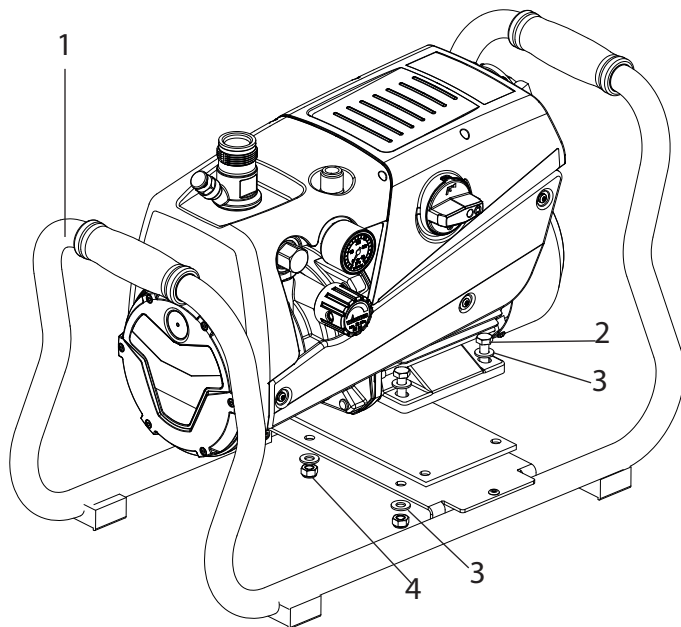

Spare parts diagram frame

11.6 SPARE PARTS LIST SUCTION SYSTEM (RIGID)

ITEM	ORDER NO.	DESIGNATION
1	2342 879	Suction system assy..
2	2323 325	Filter, mesh width 1 mm
	0250 245	Optional: Filter, mesh width 0,8 mm
3	2343 688	Return pipe
4	2342 682	Suction tube

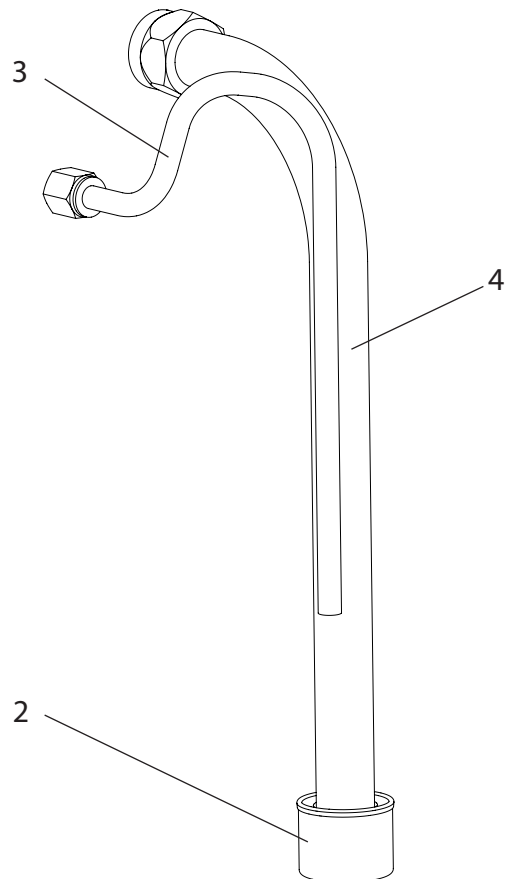

Spare parts diagram suction system (rigid)

11.7 SPARE PARTS LIST HOPPER 5L

ITEM	ORDER-NO	DESIGNATION
-	0341 265	Hopper 5l, assy.
1	0340 901	Cover
2	0037 607	Filter disk, mesh width 0,8 mm
	0003 756	Optional: Filter disk, mesh width 0,4 mm
3	9902 306	Sheet metal screw 3,9x13 (2)
4	0340 904	Hopper
5	0340 908	Return pipe

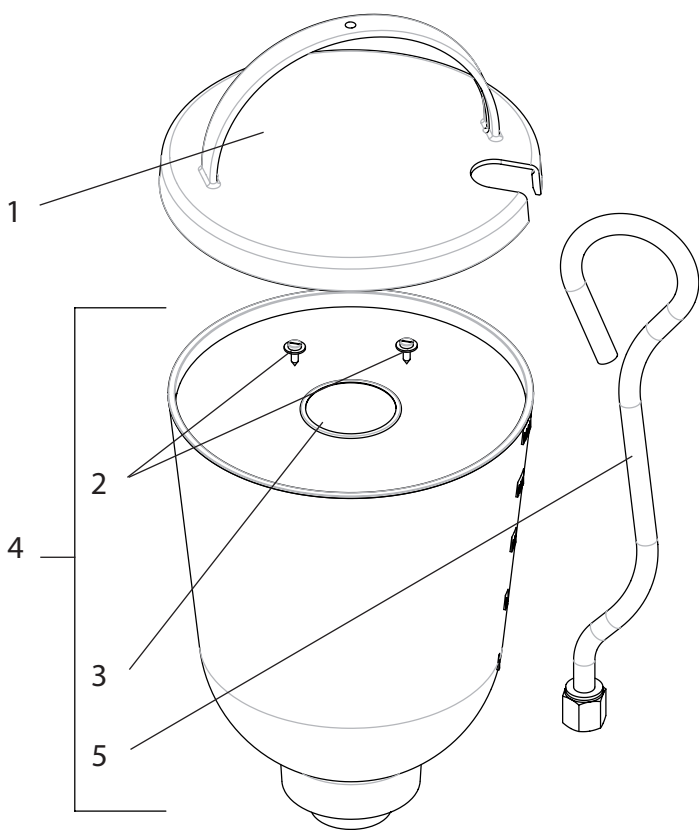

Spare parts diagram hopper

11.8 SPARE PARTS LIST HOPPER WITH TOPCLEAN

ITEM	ORDER-NO	DESIGNATION
-	0341 268	Hopper 5l with TopClean, assy.
1	0340 904	Hopper 5l (filter disc see 11.7)
2	0340 901	Cover
3	0340 271	TopClean, assy.
4	0340 270	Return pipe
5	0340 499	Screwing
6	0340 466	Distributor ring
7	0340 500	Rotary valve shaft
8	9971 486	O-ring 4x2 (FFPM)

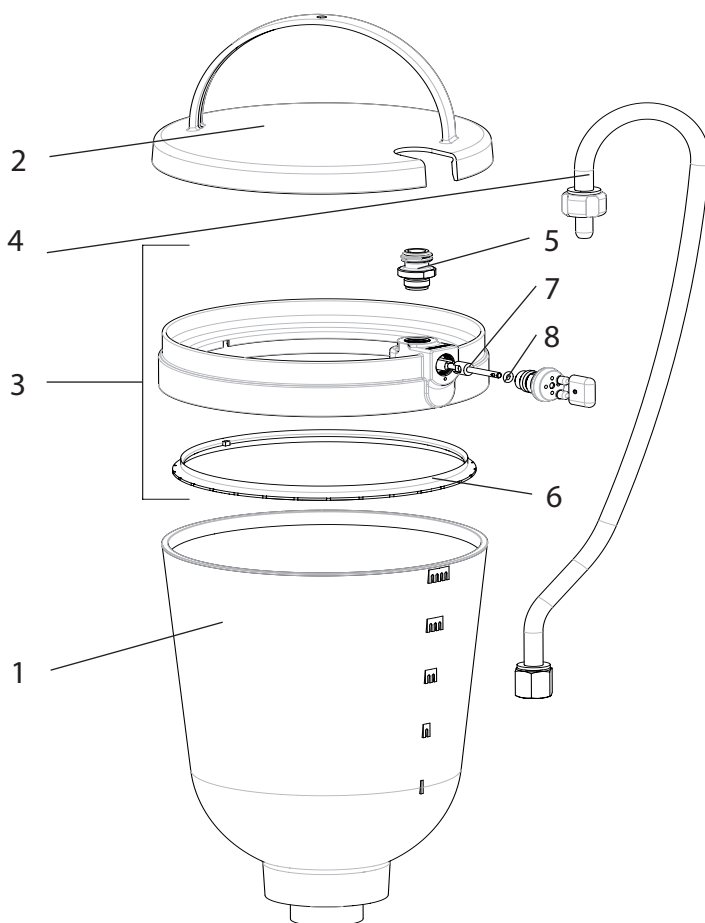

Spare parts diagram hopper with TopClean

TESTING OF THE UNIT

For safety reasons, we would recommend having the device checked by an expert as required but at least every 12 months to ensure that it can continue to operate safely.

In the case of unused devices, the check can be postponed until they are next started up.

All (potentially deviating) national inspection and maintenance regulations must also be observed.

If you have any questions, please contact the customer service team at Wagner.

IMPORTANT INFORMATION ON PRODUCT LIABILITY

According to an EU directive, the manufacturer is only liable without limitation for faults in the product if all parts come from the manufacturer or have been approved by the manufacturer and have been mounted to the device and are operated properly. If third-party accessories or spare parts are used, the manufacturer is exonerated wholly or partly from his/her liability if use of the third-party accessories or spare parts have caused a defect in the product. In extreme cases, the relevant authorities can completely prohibit using the entire device.

With original WAGNER accessories and spare parts, compliance with all safety regulations is guaranteed.

NOTE ON DISPOSAL

In observance of the European Directive 2002/96/EC on waste electrical and electronic equipment and implementation in accordance with national law, this product is not to be disposed of together with household waste material but must be recycled in an environmentally friendly way!



Wagner or one of our dealers will take back your used Wagner waste electrical or electronic equipment and will dispose of it for you in an environmentally friendly way. Please ask your local Wagner service centre or dealer for details or contact us direct.

GUARANTEE DECLARATION

(Status 01.02.2009)

1. Scope of guarantee

All Wagner professional colour application devices (hereafter referred to as products) are carefully inspected, tested and are subject to strict checks under Wagner quality assurance. Wagner exclusively issues extended guarantees to commercial or professional users (hereafter referred to as "customer") who have purchased the product in an authorised specialist shop, and which relate to the products listed for that customer on the Internet under www.wagner-group.com/profi-guarantee.

The buyer's claim for liability for defects from the purchase agreement with the seller as well as statutory rights are not impaired by this guarantee.

We provide a guarantee in that we decide whether to replace or repair the product or individual parts, or take the device back and reimburse the purchase price. The costs for materials and working hours are our responsibility. Replaced products or parts become our property.

2. Guarantee period and registration

The guarantee period amounts to 36 months. For industrial use or equal wear, such as shift operations in particular, or in the event of rentals it amounts to 12 months.

Systems driven by petrol or air are also guaranteed for a 12 month period.

The guarantee period begins with the day of delivery by the authorised specialist shop. The date on the original purchase document is authoritative.

For all products bought in authorised specialist shops from 01.02.2009 the guarantee period is extended to 24 months providing the buyer of these devices registers in accordance with the following conditions within 4 weeks of the day of delivery by the authorised specialist shop.

Registration can be completed on the Internet under www.wagner-group.com/profi-guarantee.

The guarantee certificate is valid as confirmation, as is the original purchase document that carries the date of the purchase. Registration is only possible if the buyer is in agreement with having the data being stored that is entered during registration.

When services are carried out under guarantee the guarantee period for the product is neither extended nor renewed.

Once the guarantee period has expired, claims made against the guarantee or from the guarantee can no longer be enforced.

3. Handling

If defects can be seen in the materials, processing or performance of the device during the guarantee period, guarantee

claims must be made immediately, or at the latest within a period of 2 weeks.

The authorised specialist shop that delivered the device is entitled to accept guarantee claims. Guarantee claims may also be made to the service centres named in our operating instructions. The product has to be sent without charge or presented together with the original purchase document that includes details of the purchase date and the name of the product. In order to claim for an extension to the guarantee, the guarantee certificate must be included.

The costs as well as the risk of loss or damage to the product in transit or by the centre that accepts the guarantee claims or who delivers the repaired product, are the responsibility of the customer.

4. Exclusion of guarantee

Guarantee claims cannot be considered

- for parts that are subject to wear and tear due to use or other natural wear and tear, as well as defects in the product that are a result of natural wear and tear, or wear and tear due to use. This includes in particular cables, valves, packaging, jets, cylinders, pistons, means-carrying housing components, filters, pipes, seals, rotors, stators, etc. Damage due to wear and tear that is caused in particular by sanded coating materials, such as dispersions, plaster, putty, adhesives, glazes, quartz foundation.
- in the event of errors in devices that are due to non-compliance with the operating instructions, unsuitable or unprofessional use, incorrect assembly and/or commissioning by the buyer or by a third party, or utilisation other than is intended, abnormal ambient conditions, unsuitable coating materials, unsuitable operating conditions, operation with the incorrect mains voltage supply/frequency, over-operation or defective servicing or care and/or cleaning.
- for errors in the device that have been caused by using accessory parts, additional components or spare parts that are not original Wagner parts.
- for products to which modifications or additions have been carried out.
- for products where the serial number has been removed or is illegible
- for products to which attempts at repairs have been carried out by unauthorised persons.
- for products with slight deviations from the target properties, which are negligible with regard to the value and usability of the device.
- for products that have been partially or fully taken apart.

5. Additional regulations.

The above guarantees apply exclusively to products that have been bought by authorised specialist shops in the EU, CIS, Australia and are used within the reference country.

If the check shows that the case is not a guarantee case, repairs are carried out at the expense of the buyer.

The above regulations manage the legal relationship to us conclusively. Additional claims, in particular for damages and losses of any type, which occur as a result of the product or its use, are excluded from the product liability act except with regard to the area of application.

Claims for liability for defects to the specialist trader remain unaffected.

German law applies to this guarantee. The contractual language is German. In the event that the meaning of the German and a foreign text of this guarantee deviate from one another, the meaning of the German text has priority.

J. Wagner GmbH
 Division Professional Finishing
 Otto Lilienthal Strasse 18
 88677 Markdorf
 Federal Republic of Germany

Subject to modifications · Printed in Germany

WAGNER

J. Wagner GmbH Otto Lilienthal-Str.18 D-88677 Markdorf



CE Konformitätserklärung

Hiermit erklären wir, daß die Bauart vom Airless Hochdruck-Spritzgerät



CE Declaration of conformity

Herewith we declare that the supplied version of Airless high-pressure spraying unit



CE Déclaration de conformité

Par la présente, nous déclarons, que le type de Groupe de projection à haute pression



CE Dichiarazione di conformità

Si dichiara che il modello Impianto per la verniciatura a spruzzo ad alta pressione Airless

Wagner Super Finish

SF-23plus 1~230V/50Hz; SF-23plus 1~110V/50Hz

folgenden einschlägigen Bestimmungen entspricht:

correspond aux dispositions pertinentes suivantes:

è conforme alle seguenti disposizioni pertinenti:

2006/42 EG, 2004/108 EG

2006/42 EC, 2004/108 EC

2006/42 CE, 2004/108 CE

2006/42 CE, 2004/108 CE

Angewendete harmonisierte Normen, insbesondere:

Applied harmonized standards, in particular:

Normes harmonisées utilisées, notamment:

Norme armonizzate applicate, in particolare:

DIN EN ISO 12100: 2011-03, DIN EN 1953: 2013-12, DIN EN 60204-1:2007-6,

DIN EN 61000-6-1:2007-10, DIN EN 61000-6-3:2011-09, DIN EN 61000-3-2 :2010-03, DIN EN 61000-3-3:2009-06

Angewendete nationale technische Spezifikationen, insbesondere:

Applied national technical standards and specifications, in particular:

Gebruikte nationale technische normen en specificaties, in het bijzonder:

BGR 500 /2/ Kapitel 2.29, 2.36

Markdorf, 24.10.2013

Location, Date

Senior Vice President
Global Product Strategy & Planning

Hr. T. Jeltsch (Mr.)

Vice-President Engineering

Hr. J. Ulbrich (Mr.)
Dokumentationsverantwortlicher
Responsible person for documents
Responsable de la documentation
Responsabile della documentazione

Wagner-Nr. 2343687



CE Konformiteitsverklaring

hiermede verklaren wij, dat de in de handel gebrachte machine Airless – hogedruk-spuitaapparaat



CE Konformitetserklæring

Hiermed erklæres, at produkttypen Airless – højtrykssprøjtapparat



CE Försäkran

Härmed intygar vi att Airless – högttryckspruta



CE Declaración de conformidad

por la presente, declaramos que la Airless equipo de pulverización de alta presión



CE Declaração de conformidade

Com a presente, declaramos que o Aparelho de pulverização de alta pressão Airless

Wagner Super Finish

SF-23plus 1~230V/50Hz; SF-23plus 1~110V/50Hz

voldoet aan de eisen van de in het vervolg genoemde bepalingen:

esta em conformidade com as disposições pertinentes, a saber:

2006/42 EG, 2004/108 EG

Gebruikte geharmoniseerde normen, in het bijzondere:

2006/42 EF, 2004/108 EF

Harmoniseerde standarder, der blev anvendt, i saerdeleshed:

2006/42 EC, 2004/108 EC

Tillämpade harmoniserade standarder, i synnerhet:

2006/42 CE, 2004/108 CE

Normas armonizadas utilizadas, particularmente:

2006/42 CE, 2004/108 CE

Normas harmonizadas utilizadas, em particular:

DIN EN ISO 12100: 2011-03, DIN EN 1953: 2013-12, DIN EN 60204-1: 2007-6,

DIN EN 61000-6-1:2007-10, EIN EN 61000-6-3:2011-09, DIN EN 61000-3-2: 2010-03, DIN EN 61000-3-3: 2009-06

Norme e specificazioni tecniche nazionali applicate, in particolare:

Normas y especificaciones técnicas nacionales que se utilizaron, particularmente:

Nationale standarder og tekniske specifikationer, der blev anvendt, i saerdeleshed:

Normas e especificações nacionais utilizadas, em particular:

Tillämpade nationella, tekniska specifikationer, i synnerhet:

BGR 500 /2/ Kapitel 2.29, 2.36

Markdorf, 24.10.2013

Location, Date

T. Jeltsch

Senior Vice President
Global Product Strategy & Planning

Hr. T. Jeltsch (Mr.)

J. Ulbrich

Vice President Engineering

Hr. J. Ulbrich (Mr.)
Documentatieverantwoordelijke
Dokumentationsansvarlig
Dokumentationsansvarig
Responsable de la documentación
Responsável pela documentação

EUROPA-SERVICENETZ / EUROPEAN SERVICE NETWORK / RÉSEAU DE SERVICE APRÈS-VENTE EN EUROPE**RETE DI ASSISTENZA EUROPEA / EUROPA – SERVICENETWERK**

- A** J. Wagner Ges.m.b.H.
Ottogasse 2/20
2333 Leopoldsdorf
Österreich
Tel. +43/ 2235 / 44 158
Telefax +43/ 2235 / 44 163
office@wagner-group.at
- B** WSB Finishing Equipment
Veilinglaan 56-58
1861 Meise-Wolvertem
Belgium
Tel. +32/2/269 46 75
Telefax +32/2/269 78 45
info@wagner-wsb.nl
- CH** Wagner International AG
Industriestrasse 22
9450 Altstätten
Schweiz
Tel. +41/71 / 7 57 22 11
Telefax +41/71 / 7 57 22 22
wagner@wagner-group.ch
- D** J. Wagner GmbH
Otto-Lilienthal-Straße 18
D-88677 Markdorf
Postfach 11 20
D-88669 Markdorf
Deutschland
Tel.: +49 / 75 44 / 505 -1664
Fax: +49 / 75 44 / 505 -1155
wagner@wagner-group.com
www.wagner-group.com
- DK** Wagner Spraytech
Scandinavia A/S
Helgeshøj Allé 28
2630 Taastrup
Denmark
Tel. +45/43/ 27 18 18
Telefax +45/43/ 43 05 28
wagner@wagner-group.dk
- E** Wagner Spraytech Iberica S.A.
P.O. Box 132, Crta. N-340
08750 Molins de Rey
Barcelona / Espania
Tel. +34/93/6800028
Telefax +34/93/66800555
info@wagnerspain.com
- F** Wagner France S.a.r.l
12 Avenue des Tropiques
Z.A. de Courtaboeuf
91978 Les Ulis Cedex
France
Tel. 0 825 011 111
Telefax +33 (0) 1 69 81 72 57
division.batiment@wagner-france.fr
- CZ** Wagner, spol. s r.o.
Nedasovská str. 345
155 21 Praha 5 -Zlicín
Czechia
Tel. +42/ 2 / 579 50 412
Telefax +42/ 2 / 579 51 052
info@wagner.cz
- GB** Wagner Spraytech (UK) Limited
The Coach House
2 Main Road
Middleton Cheney OX17 2ND
Great Britain
UK-Helpline 01295 714200
Fax 01295 710100
enquiries@wagnerspraytech.co.uk
- I** Wagner colora Srl
Via Italia 34
20060 Gessate – MI
Italia
Tel. 02.959292.1
Telefax 02.95780187
info@wagnercolora.com
- NL** WSB Finishing Equipment BV
De Heldinnenlaan 200,
3543 MB Utrecht
Netherlands
Tel. +31/ 30/241 41 55
Telefax +31/ 30/241 17 87
info@wagner-wsb.nl
- S** Wagner Spraytech
Scandinavia A/S
Helgeshøj Allé 28
2630 Taastrup
Denmark
Tel. +45/43/ 21 18 18
Telefax +45/43/ 43 05 28
wagner@wagner-group.dk

www.wagner-group.com